

**Salmonid Egg Research at the Pacific Biological  
Station (2002 to 2004), With Special Interest in  
Atlantic Salmon (*Salmo salar*)**

J.O.T. Jensen, T. Sweeten, W. Damon, and W.E. McLean

Fisheries and Oceans Canada  
Science Branch, Pacific Region  
Pacific Biological Station  
Nanaimo, British Columbia  
V9T 6N7

2009

**Canadian Technical Report of  
Fisheries and Aquatic Sciences 2838**



Fisheries  
and Oceans

Pêches  
et Océans

Canada 

## **Canadian Technical Report of Fisheries and Aquatic Sciences**

Technical reports contain scientific and technical information that contributes to existing knowledge but which is not normally appropriate for primary literature. Technical reports are directed primarily toward a worldwide audience and have an international distribution. No restriction is placed on subject matter and the series reflects the broad interests and policies of the Department of Fisheries and Oceans, namely, fisheries and aquatic sciences.

Technical reports may be cited as full publications. The correct citation appears above the abstract of each report. Each report is abstracted in *Aquatic Sciences and Fisheries Abstracts* and indexed in the Department's annual index to scientific and technical publications.

Numbers 1-456 in this series were issued as Technical Reports of the Fisheries Research Board of Canada. Numbers 457-714 were issued as Department of the Environment, Fisheries and Marine Service, Research and Development Directorate Technical Reports. Numbers 715-924 were issued as Department of Fisheries and the Environment, Fisheries and Marine Service Technical Reports. The current series name was changed with report number 925.

Technical reports are produced regionally but are numbered nationally. Requests for individual reports will be filled by the establishment listed on the front cover and title page. Out-of-stock reports will be supplied for a fee by commercial agents.

## **Rapport technique canadien des sciences halieutiques et aquatiques**

Les rapports techniques contiennent des renseignements scientifiques et techniques qui constituent une contribution aux connaissances actuelles, mais qui ne sont pas normalement appropriés pour la publication dans un journal scientifique. Les rapports techniques sont destinés essentiellement à un public international et ils sont distribués à cet échelon. Il n'y a aucune restriction quant au sujet; de fait, la série reflète la vaste gamme des intérêts et des politiques du ministère des Pêches et des Océans, c'est-à-dire les sciences halieutiques et aquatiques.

Les rapports techniques peuvent être cités comme des publications complètes. Le titre exact paraît au-dessus du résumé de chaque rapport. Les rapports techniques sont résumés dans la revue *Résumés des sciences aquatiques et halieutiques*, et ils sont classés dans l'index annuel des publications scientifiques et techniques du Ministère.

Les numéros 1 à 456 de cette série ont été publiés à titre de rapports techniques de l'Office des recherches sur les pêcheries du Canada. Les numéros 457 à 714 sont parus à titre de rapports techniques de la Direction générale de la recherche et du développement, Service des pêches et de la mer, ministère de l'Environnement. Les numéros 715 à 924 ont été publiés à titre de rapports techniques du Service des pêches et de la mer, ministère des Pêches et de l'Environnement. Le nom actuel de la série a été établi lors de la parution du numéro 925.

Les rapports techniques sont produits à l'échelon régional, mais numérotés à l'échelon national. Les demandes de rapports seront satisfaites par l'établissement auteur dont le nom figure sur la couverture et la page du titre. Les rapports épuisés seront fournis contre rétribution par des agents commerciaux.

Canadian Technical Report of  
Fisheries and Aquatic Sciences 2838

2009

**SALMONID EGG RESEARCH AT THE PACIFIC BIOLOGICAL STATION  
(2002 to 2004), WITH SPECIAL INTEREST IN  
ATLANTIC SALMON (*Salmo salar*)**

by

J.O.T. Jensen<sup>a,c</sup>; T. Sweeten<sup>a</sup>, W. Damon<sup>a</sup>, and W.E. McLean<sup>b</sup>

<sup>a</sup>Fisheries and Oceans Canada  
Science Branch, Pacific Region  
Pacific Biological Station  
Nanaimo, British Columbia  
V9T 6N7

<sup>b</sup>675 Hornet Way  
Comox, British Columbia  
V9M 0A2

<sup>c</sup>Retired

©Her Majesty the Queen in Right of Canada, 2009  
Cat. No. Fs 97-6/2838E ISSN 0706-6457

Correct citation for this publication:

Jensen, J.O.T., Sweeten, T., Damon, W., and McLean, W.E. 2009. Salmonid egg research at the Pacific Biological Station (2002 to 2004), with special interest in Atlantic Salmon (*Salmo salar*) Can. Tech. Rep. Fish. Aquat. Sci. 2838: vii + 47p.

## Table of Contents

Table of Contents .....	iii
1.1 List of Tables .....	iv
1.2 List of Figures .....	v
1.3 ABSTRACT .....	vii
1.4 RÉSUMÉ .....	vii
2 SHORT-TERM STORAGE OF ATLANTIC SALMON ( <i>SALMO SALAR</i> ) GAMETES AT 3 TO 12 °C OR FERTILIZED EGGS AT 8 °C .....	2.1
2.1 Abstract .....	2.1
2.2 Introduction .....	2.1
2.3 Methods .....	2.2
2.3.1 Gamete Storage Experiment .....	2.2
2.3.2 Fertilized Egg Storage Experiment .....	2.2
2.4 Results .....	2.3
2.4.1 Gamete Storage Experiment .....	2.3
2.4.2 Fertilized eggs storage Experiment .....	2.5
2.5 Discussion .....	2.7
2.6 Acknowledgements: .....	2.8
2.7 References: .....	2.8
3 CHANGES IN MECHANICAL SHOCK SENSITIVITY OF ATLANTIC SALMON ( <i>SALMO SALAR</i> ) EGGS DURING INCUBATION .....	3.1
3.1 Abstract .....	3.1
3.2 Introduction .....	3.1
3.3 Methods .....	3.2
3.3.1 Mechanical shock device .....	3.2
3.3.2 Water Temperature Measurement .....	3.4
3.3.3 Shock sensitivity .....	3.4
3.4 Results .....	3.5
3.5 Discussion .....	3.8
3.6 Acknowledgements .....	3.11
3.7 References .....	3.11
4 CHANGES IN SALMONID EGG SURVIVAL AFTER EXPOSURE TO MECHANICAL SHOCK AND TO VARIOUS CONCENTRATIONS OF IODINE ...	4.1
4.1 Abstract .....	4.1
4.2 Introduction .....	4.1
4.3 Methods .....	4.2
4.3.1 Big Qualicum: 1983/84 .....	4.3
4.3.2 Rosewall Creek: 2002 .....	4.3
4.3.3 Rosewall Creek: 2003 .....	4.3
4.3.4 Puntledge Hatchery: 2003 .....	4.4
4.4 Results .....	4.5
4.5 Discussion .....	4.10
4.6 Acknowledgements .....	4.11
4.7 References .....	4.12

5 ATLANTIC SALMON (*SALMO SALAR*) EGG AND LARVAL DEVELOPMENT AND MORTALITY RATES AT TEMPERATURES RANGING FROM 4 TO 14 °C. 5.1

5.1	Abstract.....	5.1
5.2	Introduction.....	5.2
5.3	Methods.....	5.2
5.4	Results.....	5.4
5.5	Discussion.....	5.10
5.6	Acknowledgements.....	5.11
5.7	References.....	5.11

**1.1 List of Tables**

Table 2-1.	Atlantic salmon eyed egg survival after separate gamete storage at 3 to 12 °C for storage intervals of 6 to 72 hr, from experiments conducted in 2002 ( 3 replicates) and in 2003 (4 replicates). .....	2.3
Table 2-2.	Linear regression model coefficients for eyed egg survival (%) versus separate gamete storage duration (hr) at 3, 4, 6, 8, 9, and 12 °C. ....	2.3
Table 2-3.	Atlantic salmon eyed egg survival (%) for fertilized eggs stored at 8 °C for durations of 6 to 72 hr in 2002 and 2003. ....	2.5
Table 3-1.	LD50 (drop height; cm) and lower and upper 95 confidence limits (95% CL) for fertilized, un-activated Atlantic salmon eggs.....	3.5
Table 3-2.	Un-activated salmon egg LD50s (cm) and 95% confidence limits (95% CL). .....	3.8
Table 3-3.	Shock sensitivity models for Pacific and Atlantic salmon eggs. Y represents LD50 (cm) and X represents ATUs (°C-days). ....	3.9
Table 3-4.	Minimum LD50s (cm) for salmon eggs. Note: negative values for chinook, coho, and steelhead indicate that these species are extremely sensitive at this time of development. ....	3.10
Table 3-5.	Minimum LD10 velocity (cm/sec) for Pacific and Atlantic salmon eggs... ..	3.11
Table 4-1.	Mortality (%) for Big Qualicum chinook (1983) and steelhead (1984) eggs subjected to mechanical shock (Drop Height; cm) followed by exposure to iodine (mg/L). Each treatment has 3 replicates. ....	4.5
Table 4-2.	Mortality (%) for Atlantic salmon and chinook eggs subjected to mechanical shock (Drop Height, cm) followed by exposure to iodine (mg/L) at Rosewall Creek in 2003. Control treatments have 5 replicates and drop treatments have 3 replicates. ....	4.6
Table 4-3.	LD50 (drop in cm to cause 50% mortality) and 95% confidence limits. LD10 (drop in cm to cause 10% mortality) is also shown. ....	4.7
Table 4-4.	Linear regression lines for LD50 (cm) versus iodine concentration (mg/L). Slope, intercept, R <sup>2</sup> and the number of observations (N) are shown for each group and for pooled chinook data (1983 and 2003). ....	4.8
Table 4-5.	Analysis of variance for experiments. Mean Squares, degrees of freedom, significant F values, and the “least significant difference” are shown for P < 0.05. ....	4.9
Table 4-6.	Mortality (%) for preliminary tests performed at Rosewall hatchery in 2002 with Atlantic salmon eggs. Only 2 drop heights and 2 iodine concentrations were used and eggs were tested at fertilization and 1 hour post-fertilization.....	4.10

Table 5-1. Time to 50% hatch, in hours, days, or ATUs, for Atlantic salmon eggs at 4 to 12 °C. Eggs were fertilized on November 13, 2002. ....	5.5
Table 5-2. Atlantic salmon egg to fry mortality (%) of eyed eggs and newly hatched larvae transferred from 8 °C to 10, 12, and 14 °C and for constant exposure from 4 to 14 °C. ....	5.8

## 1.2 List of Figures

Figure 2-1. Atlantic salmon eyed egg survival (%) for gametes stored at 3 to 12 °C from 6 to 72 hours. Three linear regression relationships (i.e. at 3, 9, and 12 °C) are included. ....	2.4
Figure 2-2. Time to 90 and 50% egg survival (Atlantic salmon) and fertilization success (chum salmon) for gametes stored from 3 to 12 °C. ....	2.5
Figure 2-3. Atlantic salmon eyed egg survival after fertilized egg storage at 8 °C for 6 to 72 hr. A group of 5 data points were considered outliers, likely affected by mechanical shock or unknown incubation problems. ....	2.7
Figure 3-1. Mechanical shock device for salmonid eggs (from Jensen and Alderdice, 1983). a: handle for raising carrier; b: metal carrier; c: slot for petri dish in position; d: release trigger; e: release platform; f: slot for adjustment of release platform height; g: stage frame; h: metal guide wires; i: 100-cm scale; j: base plate. Inset: showing guide wire passing through Teflon sleeve. ....	3.2
Figure 3-2. Ready to Drop. ....	3.3
Figure 3-3. After drop. ....	3.3
Figure 3-4. Eggs placed into divided Heath Tray. ....	3.4
Figure 3-5. Atlantic salmon egg LD50 log-linear shock sensitivity curve (solid line) and lower (dashed line) and upper (dotted line) 95% confidence limits from 0 to 60 ATUs at 8.2 °C. ....	3.6
Figure 3-6. Atlantic salmon egg LD50 (cm) parabolic shock sensitivity curve from 70 to 200 ATUs (°C-days). ....	3.7
Figure 3-7. Comparison of LD50s (cm) between Pacific and Atlantic salmon un-activated eggs. ....	3.8
Figure 3-8. Predicted LD50 log-linear curves for salmon eggs from 0 to 70 ATUs. ....	3.9
Figure 3-9. Predict LD50 parabolic curves for salmon 30 to 250 ATUs. ....	3.10
Figure 4-1. Lethal drop (cm) to kill 50% (LD50) of eggs versus iodine concentration mg/L for 4 groups of eggs (SH (steelhead) 1984, CN (chinook) 1983 and 2003, Salar (Atlantic salmon) 2003). ....	4.8
Figure 5-1. Baskets used for incubation. Eggs were in a single layer. One basket contained 4 replicates for mortality assessment, a second basket contained eggs used for growth rate sampling. ....	5.3
Figure 5-2. Atlantic salmon egg to fry mortality (%) at 4 to 14 °C. ....	5.4

Figure 5-3. Atlantic salmon egg development time (red circle; days) to 50% hatch from 4 to 12 °C. The modified Belehradek model “BLM” (red solid line) with 95% confidence limits (red dashed lines) shows a typical inverse relationship. The ATU (°C-days) model (blue solid line) yielded a constant of 481.15 °C-days, while ATUs calculated from the BLM model (red long & short dashed line) were curvilinear with differences (i.e. BLM-ATU models, green dashed line) ranging up to -47 days at 2°C ..... 5.5

Figure 5-4. Atlantic salmon wet weight (gm) and yolk and tissue weights (%)..... 5.6

Figure 5-5. Atlantic salmon time to 10% and 0% yolk and MAWW models versus temperature ranging from 4 to 12 °C. .... 5.6

Figure 5-6. Atlantic salmon embryo at the eyed stage..... 5.7

Figure 5-7. Abnormal Atlantic salmon embryo. .... 5.8

Figure 5-8. Atlantic salmon egg to fry mortality comparison at constant temperatures compared to eyed eggs and newly hatched larvae transferred from 8 ° C to 10, 12, and 14 °C. .... 5.9

Figure 5-9. Atlantic salmon egg and larval oxygen consumption (Ro; mg O2 per 1000 \* hr) at 4, 6, 8, and 10 °C..... 5.10

### **1.3 ABSTRACT**

Jensen, J.O.T., Sweeten, T., Damon, W., and McLean, W.E. 2009. Salmonid egg research at the Pacific Biological Station (2002 to 2004), with special interest in Atlantic Salmon (*Salmo salar*) Can. Tech. Rep. Fish. Aquat. Sci. 2838: vii + 47p.

Included in this report are 4 chapters presented at the 55th Annual Northwest Fish Culture Conference, December 7–9, 2004, Victoria Conference Centre, Victoria, British Columbia, Canada. The conference proceedings were not published and hence the results are not readily accessible. This report compiles these chapters, unaltered, except for minor error corrections and changes in page, table, and figure formatting and numbers, to provide citable references for these research results. All contributing authors from the original papers are included at the beginning of each chapter.

### **1.4 RÉSUMÉ**

Jensen, J.O.T., Sweeten, T., Damon, W., and McLean, W.E. 2009. Salmonid egg research at the Pacific Biological Station (2002 to 2004), with special interest in Atlantic Salmon (*Salmo salar*) Can. Tech. Rep. Fish. Aquat. Sci. 2838: vii + 47p.

Inclus dans ce rapport sont 4 chapitres présentés à la *55th Annual Northwest Fish Culture Conférence* qui a eu lieu du 7 au 9 décembre 2004' au *Victoria Conference Centre* de Victoria (Colombie-Britannique), Canada. Les travaux de la conférence n'ont pas été publiés et les résultats n'en sont sans doute donc pas facilement disponibles. Ce rapport reproduit ces chapitres sans modification, sauf quelques corrections et changements mineurs dans la pagination, les tableaux et la graphie des chiffres et des nombres, pour fournir des références aux résultats de ces recherches, propres à être cités. Les auteurs des documents originaux sont nommés au début de chaque chapitre.



## **2 SHORT-TERM STORAGE OF ATLANTIC SALMON (*SALMO SALAR*) GAMETES AT 3 TO 12 °C OR FERTILIZED EGGS AT 8 °C**

J.O.T. Jensen\*, W. Damon, and T. Sweeten. Fisheries and Oceans Canada, Science Branch, Pacific Biological Station, Nanaimo, BC V9T6N7.

Email: [Ted.Sweeten@dfo-mpo.gc.ca](mailto:Ted.Sweeten@dfo-mpo.gc.ca)

W.E. McLean, 675 Hornet Way Comox, British Columbia, V9M 0A2.

J. Lawrie and L. Beile, Stolt Sea Farm Inc. 1761 Redwood St., Campbell River, BC V9W 3K7.

M. Lawrie, Pan Fish Canada Ltd. 124-1334 Island Highway, Campbell River, BC V9W 8C9.

(\*denotes first author)

### **2.1 Abstract**

Atlantic salmon (*Salmo salar*) gametes were either stored separately at 3, 4, 6, 8, 9, and 12 °C or eggs were fertilized (i.e. gametes combined and water activated) and stored at 8 °C. In both methods storage duration intervals ranged from 6 to 72 hours. Comparison of egg survival as a function of storage method, temperature, and duration showed significant differences which will help fish culturists make choices to optimize egg survival when transporting gametes under various conditions. Storage of fertilized Atlantic salmon eggs at 8 °C showed no significant decrease in eyed egg survival for up to 72 hours ( $P=0.260$ ) with the caution that mechanical shock sensitivity of eggs may affect egg survival for this method of storage. For practical purposes it is recommended that storage of Atlantic salmon gametes can safely be done at 3 °C for up to 48 hours with no expected loss in viability ( $P<0.001$ ).

### **2.2 Introduction**

Salmonid fish culturists have studied short-term gamete and fertilized egg storage for many years (Billard and Jensen 1996; Jensen and Alderdice 1984) with the general consensus that lower temperatures and short storage durations will improve egg survival. This study was undertaken to simulate the two methods of storage generally used by the Atlantic salmon farming industry in British Columbia, Canada. The most common method is to store and transport gametes separately from the spawning site to the incubation facility followed by typical salmonid egg fertilization procedures. The second method is to fertilize eggs at the spawning site and ship them in containers with water to the incubation facility. Both of these methods are affected by temperature and storage duration. In addition, the second method also can be influenced by mechanical shock sensitivity which starts to increase soon after fertilization. Mechanical shock sensitivity of Atlantic salmon eggs was studied and reported elsewhere in these proceedings (Sweeten 2004) but was not included as a factor in the tests reported in this paper. By

storing gametes at 3 to 12 °C or fertilized eggs at 8 °C for periods of 6 to 72 hours, we hoped to determine optimum conditions for storage and transport.

## **2.3 Methods**

Atlantic salmon (*Salmo salar*) eggs and milt for this 2 year study were obtained from the Stolt Sea Farm freshwater broodstock site near Beaver Cove at Tsultan on the northeast coast of Vancouver Island, British Columbia, in November, 2002 and in November and December, 2003.

### **2.3.1 Gamete Storage Experiment**

Gamete storage experiments were conducted in 2002 and 2003. In both years sub-samples of eggs (i.e. about 1000 eggs from each female) were pooled from 10 females (i.e. about 400 ml eggs into 3 500-ml plastic containers; 1 container for each storage temperature) while milt was pooled (i.e. at least 10 mls from each male) from 6 males in 2002 and from 10 males in 2003 (i.e. 10 ml milt into a Whirl-Pak; 1 Whirl-Pak for each storage temperature). In 2003, the 3 storage temperatures used were 3, 6, and 9 °C, while in 2002, the storage temperatures used were 4, 8, and 12 °C. Initially, the containers of gametes were placed in 3 insulated storage boxes, each with ice packs or water used to approximate one of the 3 storage temperatures for the 5-hr trip to the Pacific Biological Station (PBS), Nanaimo, British Columbia. Here, the containers of gametes were placed in computer-controlled water baths set to the 3 test storage temperatures. At storage times of 6, 12, 24, 48, and 72 hr post-spawning (time zero was set at the time when the last gamete sample was obtained from the spawners; total spawning time was about 1 hr), samples of about 100 eggs per replicate (i.e. 3 replicates in 2002 and 4 replicates in 2003) were gently removed from each storage temperature and were fertilized with 0.3ml milt per replicate. Eggs were placed in divided compartments in a Heath Techna vertical flow incubator tray (Billard and Jensen 1996), with water at 8°C, and egg survival to the late eyed stage was determined.

### **2.3.2 Fertilized Egg Storage Experiment**

From the same pooled eggs and pooled milt used in the gamete storage experiment above, a total of 15 (in 2002) and 20 (in 2003) 500-ml containers of pooled eggs (i.e. 20 ml or about 100 eggs per container) were each fertilized with 0.5 ml of pooled milt and activated with freshwater at approximately 8 °C. After one minute, water was decanted and 500 ml of clean freshwater was used to top-up the containers, which were then sealed with a plastic lid. All containers were then placed in an insulated box and transported to PBS where the containers were removed from the transport box and placed in Heath Techna vertical flow trays with flowing water at 8 °C. Eggs from 3 replicate containers at 6, 9, 12, 18, and 24 hour intervals (2002) and 4 replicate containers (2003) at 6, 12, 24, 48, and 72 hour intervals were removed from the vertical flow trays and the eggs were poured into divided compartments in a Heath Techna vertical flow tray at 8 °C. During all stages of storage and transport, eggs were carefully handled to minimize the impact of mechanical shock. Egg survival to just prior to hatch was determined.

## 2.4 Results

### 2.4.1 Gamete Storage Experiment

The effects of gamete storage on eyed egg survival were determined for each storage temperature and duration (Table 2-1). The eyed egg survival data were modeled for each storage temperature to yield the linear regression equations (Table 2-2).

**Table 2-1.** Atlantic salmon eyed egg survival after separate gamete storage at 3 to 12 °C for storage intervals of 6 to 72 hr, from experiments conducted in 2002 ( 3 replicates) and in 2003 (4 replicates).

Storage Time (hr)	Replicate	2002			2003				
		4 °C eyed egg survival (%)	8 °C eyed egg survival (%)	12 °C eyed egg survival (%)	3 °C Egg Survival (%) Dec	6 °C Egg Survival (%) Nov	6 °C Egg Survival (%) Dec	9 °C Egg Survival (%) Nov	6 °C Egg Survival (%) Dec
6	1	65.5	88.7	83.6	80.0	72.9	86.5	76.2	78.9
6	2	71.0	82.5	88.4	81.3	77.3	82.4	69.7	82.2
6	3	83.3	90.0	77.9	79.9	77.7	77.6	73.9	77.2
6	4				77.9	79.2	84.4	77.9	74.6
12	1	88.5	89.4	94.0	82.9	69.9	86.4	74.7	83.6
12	2	88.1	96.1	90.7	79.3	67.3	84.8	71.1	89.7
12	3	85.9	95.5	83.5	86.5		82.2	75.4	82.1
12	4				66.7	74.0	78.2	81.9	77.1
24	1	70.2	85.0	61.1	74.1	70.9	91.5	68.1	75.2
24	2	81.5	94.3	55.1	80.5	69.3	86.9	60.4	80.0
24	3	63.6	86.8	61.6	76.3	74.7	89.6	71.7	73.6
24	4				77.3	68.2	82.0	70.0	84.8
48	1	63.9	82.6	19.1	78.4	53.6	78.6	41.9	56.7
48	2	50.9	89.3	7.7	77.1	63.9	76.2	58.5	56.0
48	3	64.4	86.9	14.9	82.2	55.8	72.0	38.2	61.0
48	4				70.7	55.8	67.7	44.1	61.9
72	1	75.3	42.1	0.0	53.8	42.0	44.8	40.9	37.4
72	2	75.0	43.6	0.0	56.5	39.2	51.4	32.4	19.4
72	3	68.8	54.2	0.0	46.0	44.1	60.7	36.0	28.3
72	4				65.2	41.0	47.4	45.6	26.1

**Table 2-2.** Linear regression model coefficients for eyed egg survival (%) versus separate gamete storage duration (hr) at 3, 4, 6, 8, 9, and 12 °C.

Storage temperature (°C)	Linear equation	R <sup>2</sup>	N
3	Y = -0.3228x + 84.073	0.5680	20
4	Y = -0.1663x + 78.448	0.1514	15
6	Y = -0.5019x + 85.949	0.6916	40
8	Y = -0.5883x + 99.527	0.6745	15
9	Y = -0.7063x + 85.749	0.8405	40
12	Y = -1.4369x + 95.730	0.9348	15

Figure 2-1 illustrates the effect of storage temperature and duration, with the linear regression lines for 3, 9, and 12 °C emphasizing the increase in rates of decline of gamete viability at higher storage temperatures.

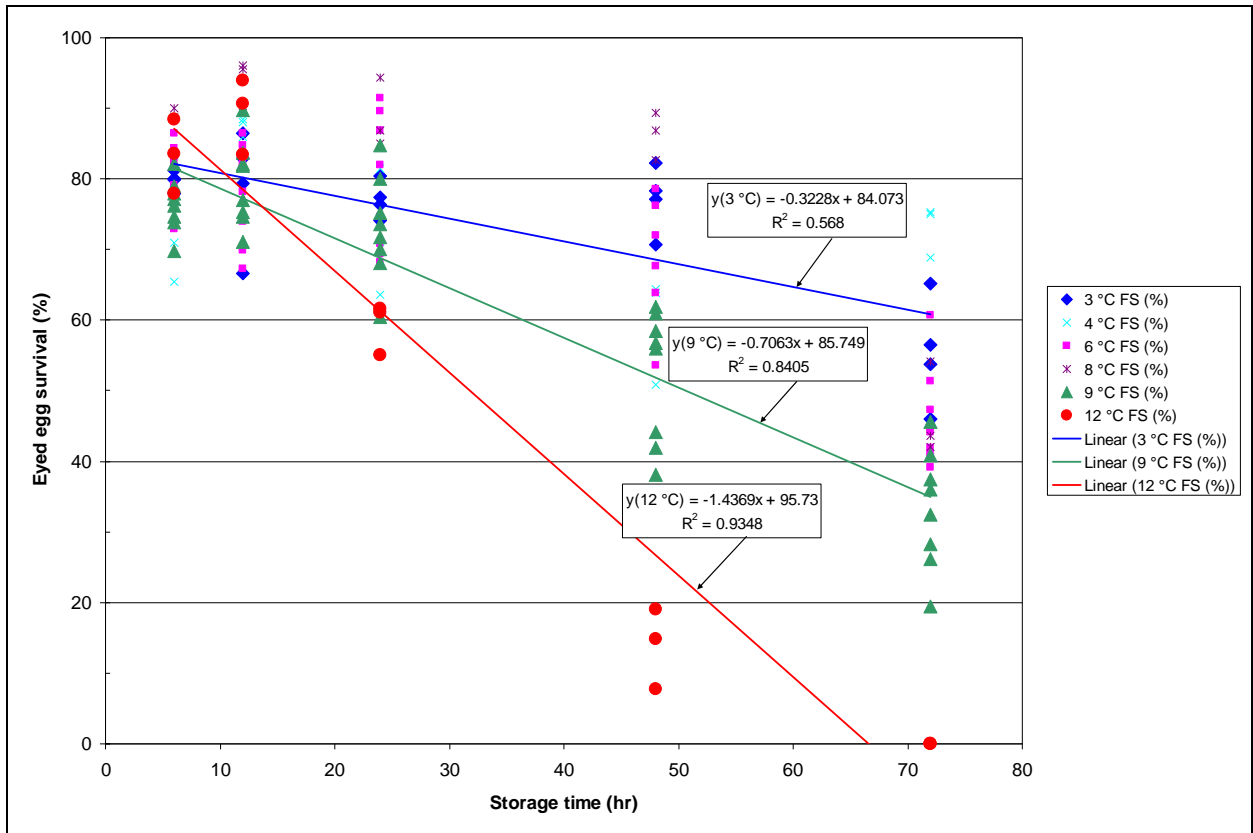

**Figure 2-1.** Atlantic salmon eyed egg survival (%) for gametes stored at 3 to 12 °C from 6 to 72 hours. Three linear regression relationships (i.e. at 3, 9, and 12 °C) are included.

Each of the linear regression equations in Table 2-2 were used to calculate 50 % egg survival which yielded the following log-linear relationship.

$$y(\text{time to 50 \% egg survival; Lnhr}) = -0.3504x(^{\circ}\text{C}) + 5.5875; R^2 = 0.8038; n=6 \quad \text{Eq. 1}$$

Only the 8 and 12 °C equations (Table 2-2) were used to, predict 90 % survival. The equation for this relationship is:

$$y(\text{time to 90 \% egg survival; Lnhr}) = -0.1563x(^{\circ}\text{C}) + 5.4091; R^2 = 1; n=2 \quad \text{Eq. 2}$$

A comparison of Atlantic salmon egg survival and chum salmon (*Oncorhynchus keta*) gamete storage times to 50 and 90% fertilization success (FS) (Jensen and Alderdice 1984) was made (Fig. 2-2). This comparison indicates similar trends for the 2 species, with Atlantic salmon gametes showing a more rapid loss in egg survival than chum salmon gametes.

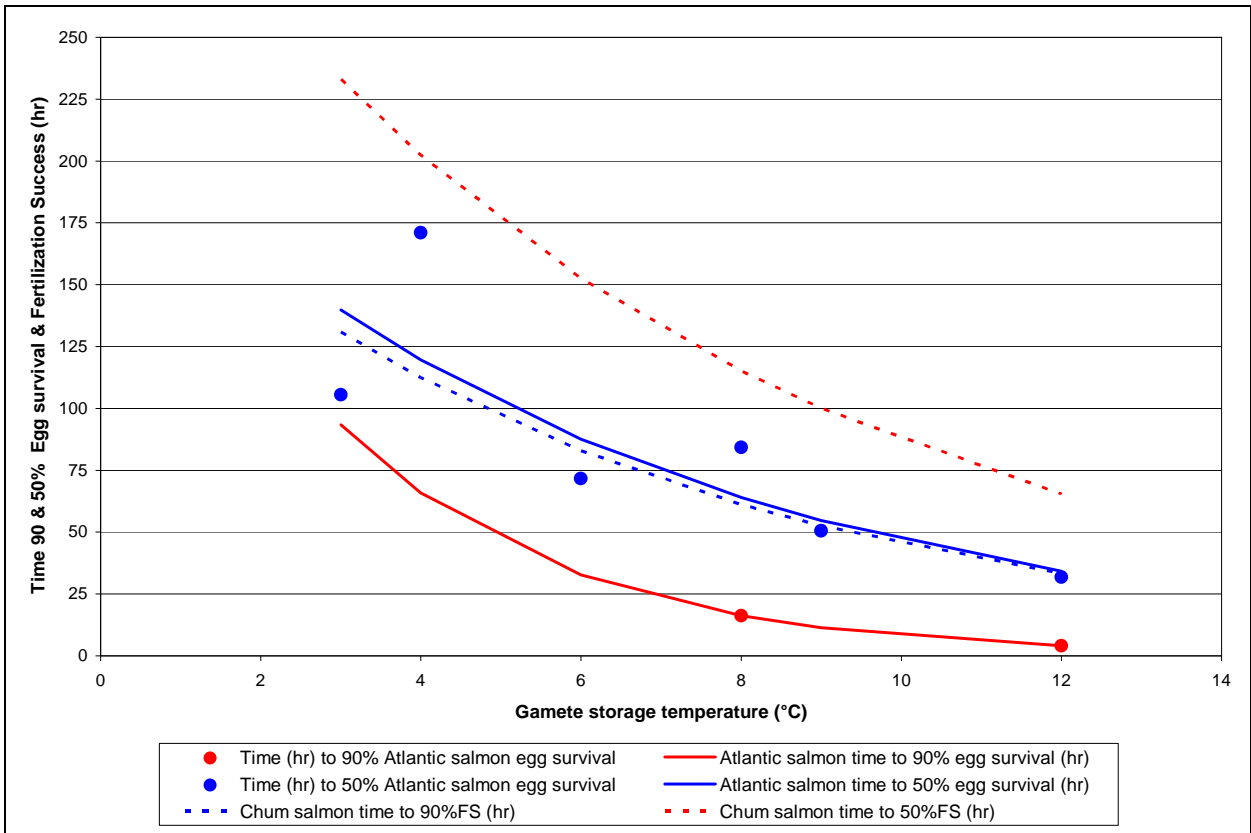

**Figure 2-2.** Time to 90 and 50% egg survival (Atlantic salmon) and fertilization success (chum salmon) for gametes stored from 3 to 12 °C.

## 2.4.2 Fertilized Eggs Storage Experiment

Eyed egg survival was determined for each storage temperature and duration (Table 2-3). Reasons for the “outlier” data with low survival were not determined may possible be caused by mechanical shock or unknown incubation problems.

**Table 2-3.** Atlantic salmon eyed egg survival (%) for fertilized eggs stored at 8 °C for durations of 6 to 72 hr in 2002 and 2003.

Storage Time (hr)	Replicate	2002	2003	
		Eye egg survival (%)	Eyed-egg survival (%)	"Outlier" Eyed-egg survival (%)
6	1	80.0	80.2	
	2	80.7	78.6	
	3	81.9	79.1	
	4		71.7	
9	1	82.6		
	2	81.8		
	3	76.2		

Storage Time (hr)	Replicate	2002	2003	
		Eye egg survival (%)	Eyed-egg survival (%)	"Outlier" Eyed-egg survival (%)
12	1	86.3	73.9	
12	2	81.0		29.5
12	3	66.1		28.7
12	4		79.2	
18	1	80.6		
18	2	84.5		
18	3	85.6		
24	1	82.6	74.2	
24	2	82.5		17.8
24	3	80.5		40.9
24	4		75.9	
48	1		71.6	
48	2		62.6	
48	3			29.5
48	4		79.0	
72	1		84.0	
72	2		78.2	
72	3		78.3	
72	4		78.2	

Data indicate that, with careful handling and incubation, newly fertilized Atlantic salmon eggs can be safely stored in water at 8 °C (i.e. 20 ml eggs in 500 ml water) for up to 72 hr with no apparent decrease in egg survival (Fig. 2-3).

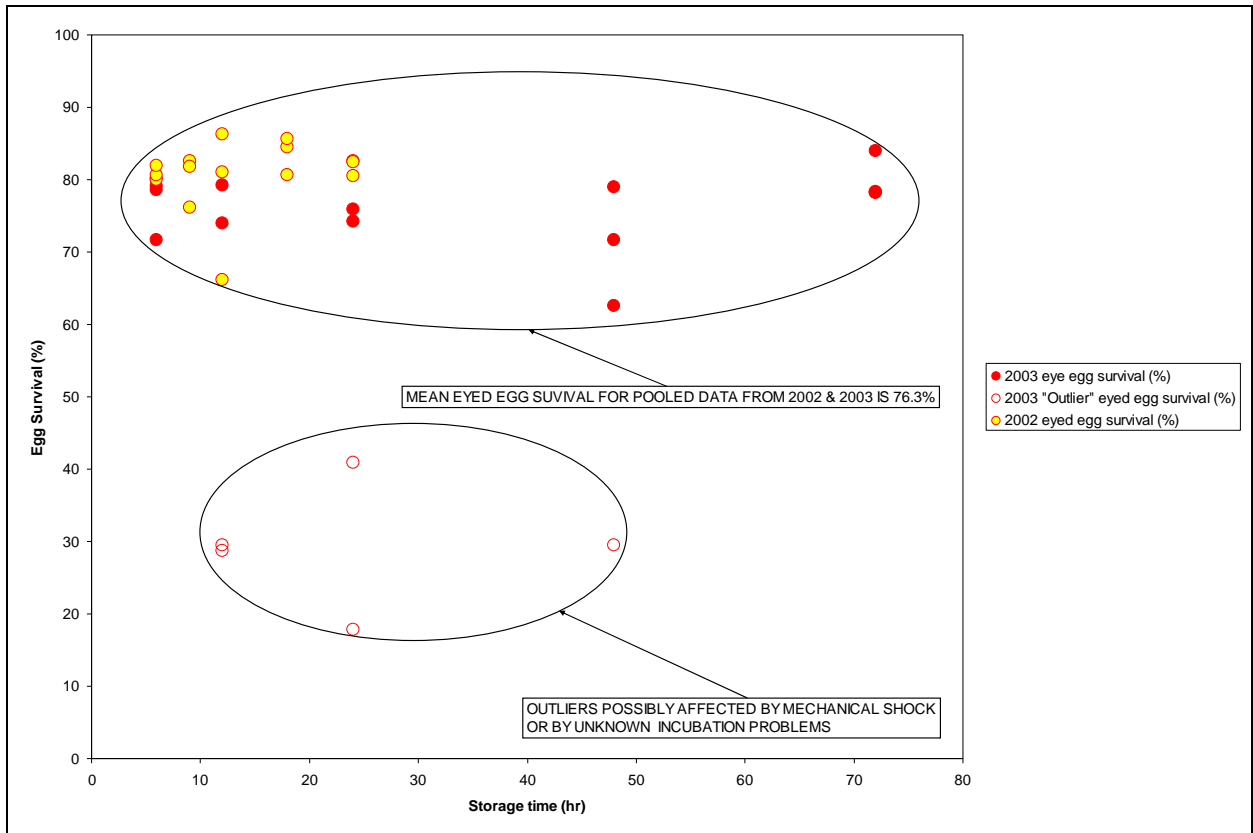

**Figure 2-3.** Atlantic salmon eyed egg survival after fertilized egg storage at 8 °C for 6 to 72 hr. A group of 5 data points were considered outliers, likely affected by mechanical shock or unknown incubation problems.

## 2.5 Discussion

Storage of Atlantic salmon gametes at temperatures ranging from 3 to 12 °C for storage intervals of up to 72 hours yielded typical decline in viability, indicated by eyed egg survival, as storage temperatures and storage duration increased. This is evidenced by the general increase in negative slopes of the linear regression equations with increased storage temperature (Table 2-2 and Fig. 2-1). The 90 and 50% eyed egg survival log-linear relationships (i.e. Eq. 1 & 2) when plotted for each storage temperature showed similar trends to those reported for chum salmon by Jensen and Alderdice (1984). The comparison (Fig. 2-2) of the 2 species indicated that stored Atlantic salmon gametes decline in viability more rapidly than chum salmon gametes at all storage temperatures and durations. For practical purposes it is recommended that storage of Atlantic salmon gametes can safely be done at 3 °C for up to 48 hours with no expected loss in viability (i.e. ANOVA of 3°C gamete storage eyed egg survival data from Table 2-1 showed no significant difference  $P < 0.001$  up to 48 hr).

Storage of fertilized Atlantic salmon eggs at 8 °C showed no significant decrease in eyed egg survival for up to 24 hours in 2002 (i.e.  $P = 0.724$ ; data in Table 2-3) and for up to 72 hours in 2003, with 5 outlier data points excluded (see Fig. 2-3), (i.e.  $P = 0.260$ ; data in

Table 2-3). Outlier data points, highlight reduced survival can occur due to unknown factors other than storage temperature and duration, and emphasizes the greater risks associated with fertilized egg storage method. Hence, this method of storage is considered inferior to storing gametes separately. It is recommended that the best method of short-term storage of Atlantic salmon is to store gametes separately, cooled to 3 °C.

## **2.6 Acknowledgements**

Funding for this project was made available through collaboration with Fisheries and Oceans Canada, Pan Fish Canada Ltd., and Stolt Sea Farm Ltd. The authors would like to thank Dale Gowan and the staff at the Stolt Sea Farm Tsultan freshwater broodstock site for their assistance in obtaining gametes.

## **2.7 References**

- Billard, R., and Jensen, J.O.T. 1996. Gamete removal, fertilization and incubation. In Principles of salmonid culture. Eds. W. Pennell and B.A. Barton, Elsevier publ. 291-364.
- Jensen, J.O.T., and Alderdice. D.F. 1984. Effect of temperature on short-term storage of eggs and sperm of chum salmon (*Oncorhynchus keta*). Aquaculture. 37: 251-265.
- Sweeten, T., Jensen, J.O.T., Damon, W., McLean, W.E., Lawrie, J. Beile, L., and Lawrie, M. Changes in Mechanical Shock Sensitivity of Atlantic Salmon (*Salmo salar*) Eggs during Incubation. In Proc. 47th Northwest Fish Culture Conference, Victoria, British Columbia, Canada, Dec. 7-9th, 2004.

### 3 CHANGES IN MECHANICAL SHOCK SENSITIVITY OF ATLANTIC SALMON (SALMO SALAR) EGGS DURING INCUBATION

T. Sweeten \*, J.O.T. Jensen, and W. Damon, Fisheries and Oceans Canada, Science Branch, Pacific Biological Station, Nanaimo, BC V9T6N7. Email: [Ted.Sweeten@dfo-mpo.gc.ca](mailto:Ted.Sweeten@dfo-mpo.gc.ca)

W.E. McLean, 675 Hornet Way Comox, British Columbia, V9M 0A2.

J. Lawrie and L. Beile, Stolt Sea Farm Inc. 1761 Redwood St Campbell River, BC V9W 3K7.

M. Lawrie, Pan Fish Canada Ltd. 124-1334 Island Highway, Campbell River, BC V9W 8C9.

(\*denotes first author)

#### 3.1 Abstract

Atlantic salmon eggs (*Salmo salar*), from fertilization to hatch, were exposed to controlled levels of mechanical shock utilizing a device designed to drop eggs from a maximum height of 1 meter. Groups of eggs, incubating at 8 °C, were exposed to a series of standardized shock intensities over many intervals. After shocking, egg mortality and normal embryo development were monitored. The lethal drop (LD) heights causing 50% and 10% mortality (i.e. LD50 and LD 10) were determined and compared to Pacific salmon eggs. In addition, LD10 velocities (i.e. the velocity reached when eggs are dropped from a height that causes 10% mortality) were calculated to assess “safe” levels of exposure to peak particle waves generated by seismic shock events. Atlantic salmon egg shock sensitivity falls within the levels reported for Pacific salmon eggs. Un-activated Atlantic salmon eggs are the third most sensitive of the species tested. During the early phase of embryonic development (i.e. 0 to 60 ATUs), Atlantic salmon eggs are more resistant to shock than most other salmon eggs tested. However, during the most sensitive period of development (i.e. from 70 to 200 ATUs), Atlantic salmon eggs exhibited the second highest shock sensitivity of all the species tested, with a minimum LD10 velocity value of 20.9 cm/sec.

#### 3.2 Introduction

During incubation, salmonid eggs are sensitive to mechanical shock (vibration, tumbling, pouring, and handling). The level of shock sensitivity increases to a maximum during yolk overgrowth or epiboly, followed by a decrease in shock sensitivity after yolk plug closure. By the eyed stage (i.e. visible well-pigmented eye in the embryo) the eggs are fairly resistant to shock, and thus can be handled to allow dead egg removal for fungus control and for inventory enumeration.

Shock sensitivity relationships have been determined for chinook (*Oncorhynchus tshawytscha*), chum (*O. keta*), coho (*O. kisutch*), pink (*O. gorbuscha*), sockeye (*O. nerka*), and rainbow or steelhead trout (*O. mykiss*), by Jensen and Alderdice (1983, 1989). The same techniques and equipment used by Jensen and Alderdice (1983, 1989) were used to determine Atlantic salmon (*Salmo salar*) egg shock sensitivity relationships. It is hoped that this research will improve our

understanding of mechanical shock sensitivity of Atlantic salmon eggs and that our findings will be of assistance to fish culturists.

Materials and methods

### 3.3 Methods

#### 3.3.1 Mechanical Shock Device

A device described by Jensen and Alderdice (1983, 1989) was used to drop 30 to 50 eggs up to 100 cm to determine shock sensitivity (Fig. 3-1). A sample of eggs drained of water was placed in a 60 mm petri dish, which was then placed in the carrier and dropped (Fig. 3-2). The eggs were removed from the carrier (Fig. 3-3) and placed in a Plexiglas compartment of a vertical flow incubation tray (Heath Techna Inc.)(Fig. 3-4). All tests were conducted at the Rosewall Creek hatchery (central Vancouver Island); a Salmon Enhancement facility noted for a good ground water supply and constant water temperature.

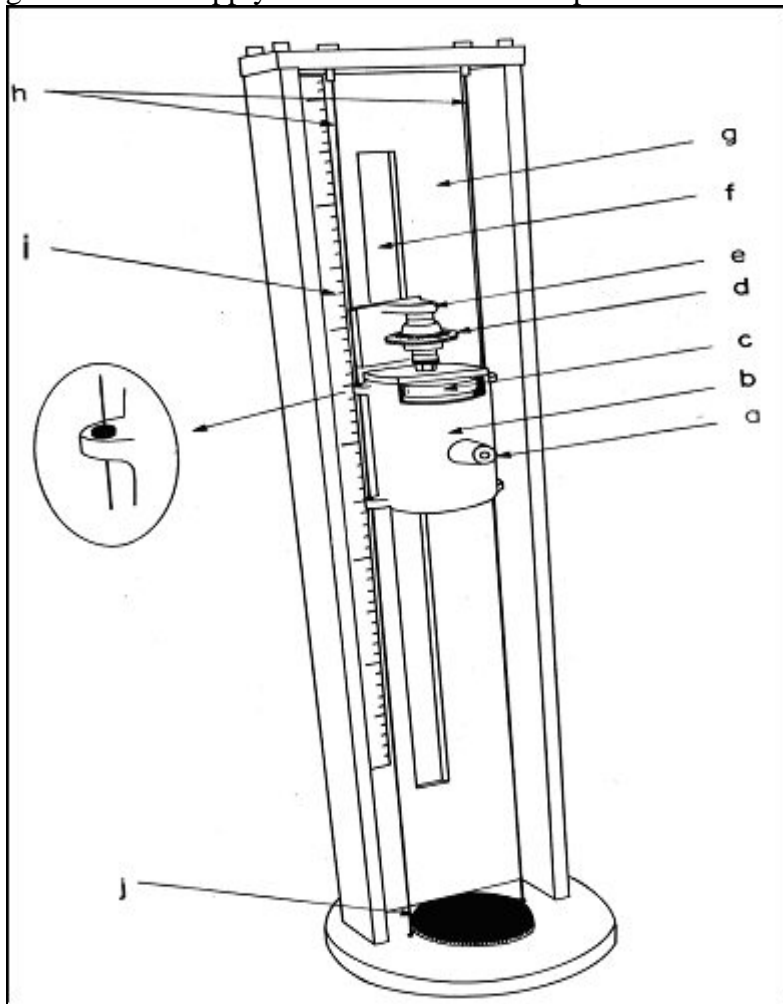

**Figure 3-1.** Mechanical shock device for salmonid eggs (from Jensen and Alderdice, 1983). a: handle for raising carrier; b: metal carrier; c: slot for petri dish in position; d: release trigger; e: release platform; f: slot for adjustment

of release platform height; g: stage frame; h: metal guide wires; i: 100-cm scale; j: base plate. Inset: showing guide wire passing through Teflon sleeve.



**Figure 3-2.** Ready to Drop.



**Figure 3-3.** After drop.



**Figure 3-4.** Eggs placed into divided Heath Tray.

### **3.3.2 Water Temperature Measurement**

Water temperature was measured and logged every 15 minutes by an Onset TidbiT portable temperature logger which was placed in the top of the vertical flow incubation stack. The daily average water temperature, in °C, was summed over the length of the experiment to get accumulated temperature units (ATUs; °C -days).

### **3.3.3 Shock Sensitivity**

Gametes for the test came from Pan Fish broodstock site at Glacial Bay in Jervis Inlet on the Sunshine Coast. They were kept separate and cool (3 °C) until fertilized 4-8 hours after collection. The eggs and sperm from 5 females and 5 males were pooled. The eggs were activated and incubated in 8 °C at Rosewall Creek Hatchery. Water activation times for the initial shock tests up to 4 hours were staggered to ensure that each shock test, including each replicate, was conducted at the same exact time post-activation. For shock tests performed for durations longer than 4 hours post-activation, eggs and sperm were placed into two Heath trays, from which eggs were gently removed for shock tests for the remainder of the egg incubation period. A test of fertilized but un-activated “green” eggs was also included.

For control samples (i.e. to account for any mortality occurring from the procedures required to move eggs to and from the incubator tray and the shock device), the eggs were placed in the carrier, but not dropped. For the shock samples, five drop heights were used at each time interval (5-100 cm). In 2002, 2 replicates were used for both controls and test drop heights, while in 2003, 5 replicates were used for controls and 3 replicates for test drop heights. The control and test eggs were placed in divided heath trays, with a flow of 10 lpm. In the first year of tests, eggs were fertilized on Nov 19, 2002 and monitored until March 20, 2003 at an average temperature of 8.06 °C. In the following year fertilization occurred on November 25, 2003 and eggs were monitored until March 22, 2004 at an average temperature of 8.4 °C

Because of problems with egg fertilization in 2002, and hence large variation in mortality among control and shock tests, only the data beginning at 70 ATU (8 to 30, 40, 50, 51, 55, 56 days) were used to determine LD50s. In 2003, the first 7 days of the experiment (i.e. post-activation times of 5, 10, 15, 30 minute, 1, 2, 4, 8, 12, 24 hour, 2-7 day) were re-tested.

Probit analyses was used to generate LD50s (Jensen and Alderdice 1983) for mortality data from fertilization to 300 ATUs. LD10s (i.e. drop height causing 10% mortality) were calculated from the probit slopes and y-intercepts. The LD10s were used to determine the corresponding final velocity reached by the eggs (i.e. LD10 velocity) (Jensen 2003).

A curve fitting program (TableCurve 2D by Systat Software Inc.) was used to fit a log-linear relation between y (LD50cm) and x (ATU):  $y = a + b \ln x$  for the first 60 ATU. After 70 ATU a parabola:  $(y = a + bx + cx^2)$  was fitted to the data. The latter model was used to determine the point of minimum drop height or maximum sensitivity (Jensen 2003) for the developing eggs.

### 3.4 Results

Shock sensitivity data from two years (2002/03 and 2003/04) was pooled to calculate LD50 as a function of time (Table 3-1, Fig. 3-5 and Fig. 3-6). Fertilized but un-activated eggs (i.e. not placed in water “green” egg) were more sensitive to shock (LD50 = 60.6 cm) than fertilized eggs that had been water activated for 5 minutes (LD50 = 97.0 cm).

**Table 3-1.** LD50 (drop height; cm) and lower and upper 95 confidence limits (95% CL) for fertilized, un-activated Atlantic salmon eggs

Species	LD50 (cm)	95% CL -	95% CL +
Atlantic salmon	60.6	56.5	64.9

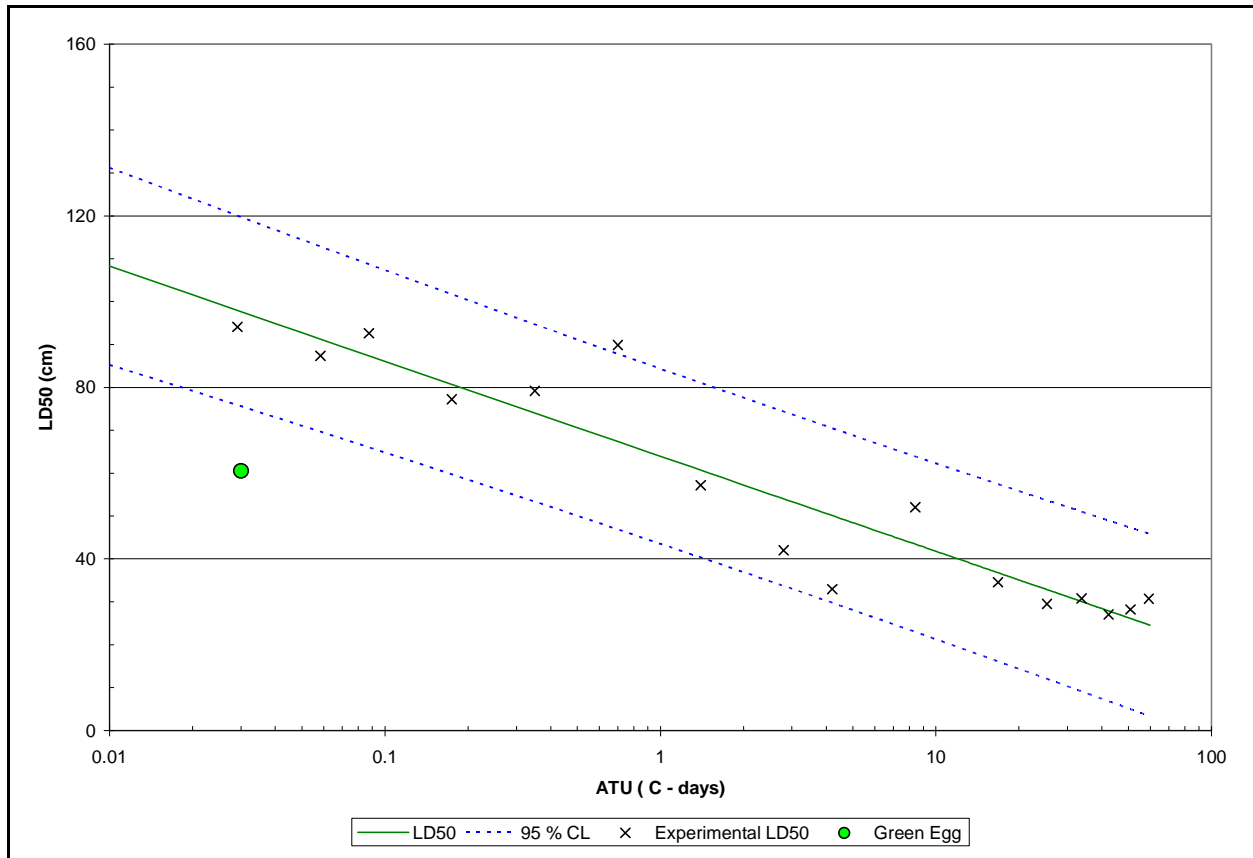

**Figure 3-5.** Atlantic salmon egg LD50 log-linear shock sensitivity curve (solid line) and lower (dashed line) and upper (dotted line) 95% confidence limits from 0 to 60 ATUs at 8.2 °C.

Over the first week of development (60 ATUs or approximately 7.3 days at 8.2 °C), shock sensitivity steadily increased (i.e. LD50 decreased). The linear relationship is as follows

$$Y = 63.9396 - 9.6211 \ln X \quad R^2 = 0.8893; n=16$$

where Y = LD50 (cm) and X = ATUs (°C-days).

The un-activated group (LD50 = 60.6 cm) is indicated in Fig. 3-5 as “Green egg” and was not included in this relationship.

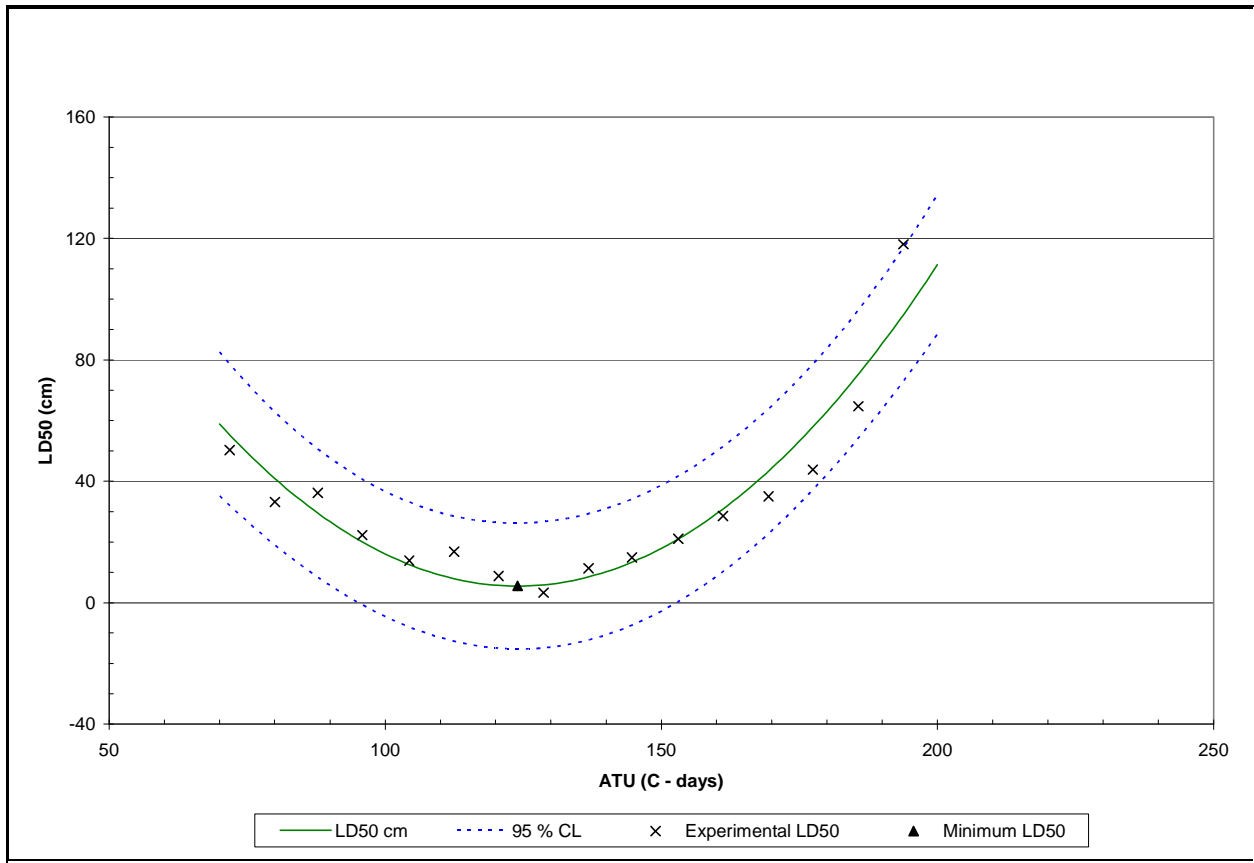

**Figure 3-6.** Atlantic salmon egg LD50 (cm) parabolic shock sensitivity curve from 70 to 200 ATUs (°C-days).

Figure 3-6 illustrates the parabolic relationship between 70 and 200 ATUs (approximately 8.5 d and 24.4 d at 8.2 °C) and the equation is as follows

$$Y = 287.2690 - 4.5453X + 0.0183 X^2 \quad R^2 = 0.8893; n=16$$

where Y = LD50 (cm) and X = ATUs (°C-days).

At the time of minimum LD50 or maximum sensitivity, the above relationship predicts that 50% mortality occurs if the eggs are dropped 5.6 cm; this corresponds to a velocity at impact of 104.8 cm/s. A similar analysis of LD10 as a function of ATU showed that the minimum LD10 occurred at 128 ATU at a drop height of 0.22 cm. This corresponds to a velocity at impact of 20.8 cm/s.

### 3.5 Discussion

The results allow comparison of the shock sensitivity of Atlantic salmon and Pacific salmon eggs (Jensen and Alderdice 1989). For fertilized un-activated eggs Atlantic salmon egg sensitivity falls between coho and chinook salmon (Table 3-2 and Fig. 3-7). This comparison indicates that un-activated Atlantic salmon eggs are among the most sensitive species of those tested and should be handled very gently prior to fertilization and activation with water.

**Table 3-2.** Un-activated salmon egg LD50s (cm) and 95% confidence limits (95% CL).

Species	LD50 (cm)	95% CL -	95% CL +
Chum	35.5	29.0	43.5
Coho	54.2	47.2	62.1
Atlantic salmon	60.6	56.5	64.9
Chinook	78.5	71.4	87.1
Steelhead	89.2	74.1	107.3
Sockeye	106.2	76.6	149.9
Pink	112.0	47.1	129.2

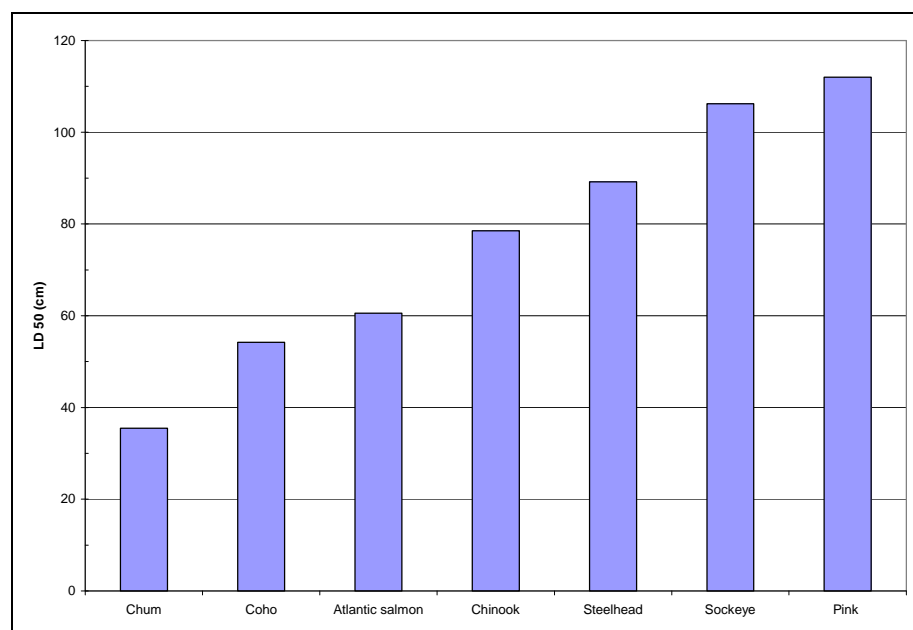
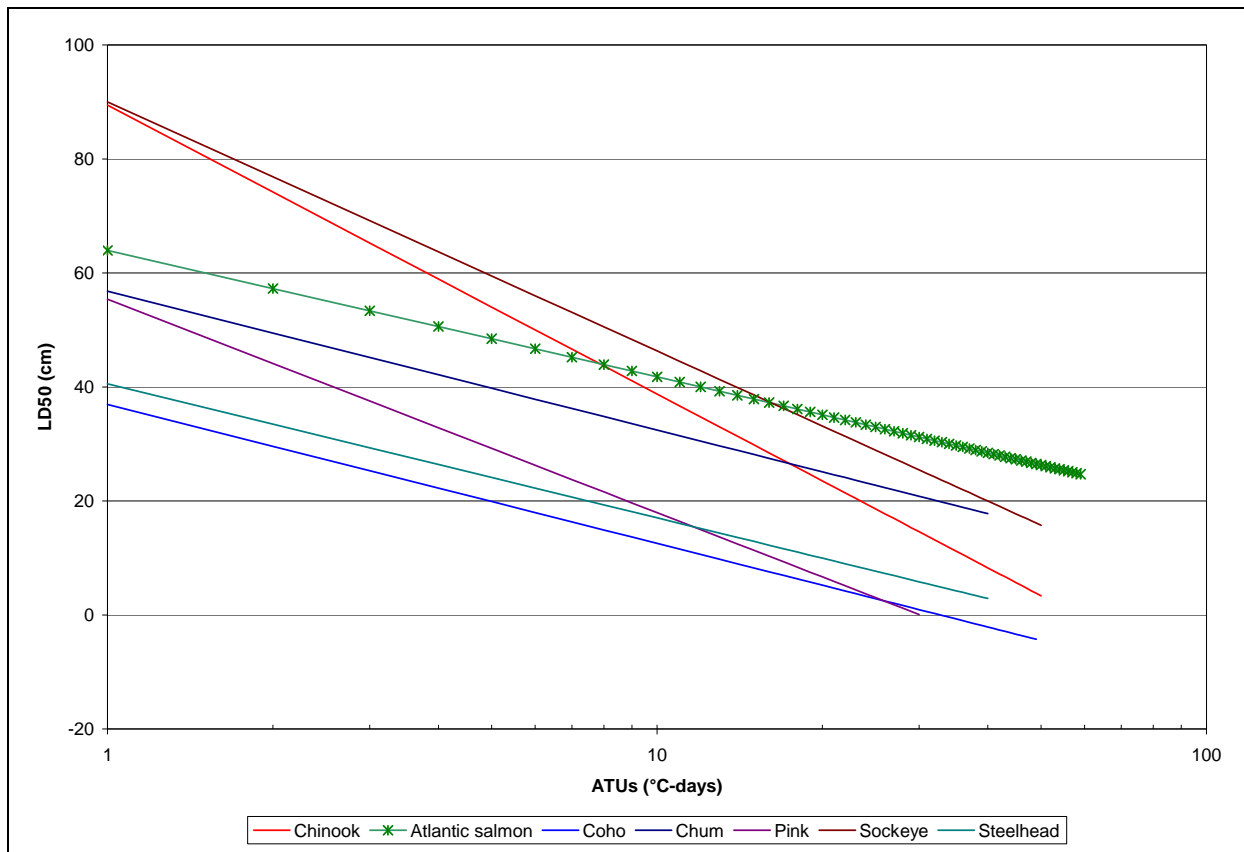

**Figure 3-7.** Comparison of LD50s (cm) between Pacific and Atlantic salmon un-activated eggs.

During early development (up to 60 ATUs), all species (note the models for the Pacific salmon species were newly generated, with time periods [i.e. ATUs] indicated and no exclusion of outliers, from the same raw data used by Jensen and Alderdice 1989) show a steady increase in sensitivity, indicated by a linear decrease in LD50 as a function of the log of ATU. Model coefficients for the different species are shown in Table 3-3 and predicted LD50 values are plotted in Figs. 3-8 and 3-9.

**Table 3-3.** Shock sensitivity models for Pacific and Atlantic salmon eggs. Y represents LD50 (cm) and X represents ATUs ( $^{\circ}\text{C}\text{-days}$ ).

Species	Model type	Model coefficients			Time period ATUs	n	$R^2$
		a	b	c			
Chinook	$y=a+b\ln x$	89.4382	-22.0048		0 - 50	14	0.874338
	$y=a+bx+cx^2$	198.3172	-3.9866	0.0175	50 - 230	14	0.780007
Chum	$y=a+b\ln x$	56.8127	-10.5833		0 - 40	13	0.529776
	$y=a+bx+cx^2$	72.5059	-1.3262	0.0061	60 - 240	20	0.971673
Coho	$y=a+b\ln x$	36.9368	-10.5855		0 - 50	16	0.686024
	$y=a+bx+cx^2$	117.5622	-2.4077	0.0114	50 - 180	5	0.895060
Pink	$y=a+b\ln x$	55.3994	-16.2661		0 - 30	13	0.762435
	$y=a+bx+cx^2$	77.1386	-1.5710	0.0093	30 - 190	17	0.809475
Sockeye	$y=a+b\ln x$	90.0410	-18.9923		0 - 50	16	0.733368
	$y=a+bx+cx^2$	144.0172	-2.6759	0.0134	50 - 200	16	0.915053
Steelhead	$y=a+b\ln x$	40.5516	-10.2118		0 - 40	15	0.664983
	$y=a+bx+cx^2$	94.7830	-2.5010	0.0159	40 - 150	12	0.867079
Atlantic salmon	$y=a+b\ln x$	63.9363	-9.6211		0 - 60	16	0.889292
	$y=a+bx+cx^2$	287.2690	-4.5453	0.0183	70 - 200	16	0.936795



**Figure 3-8.** Predicted LD50 log-linear curves for salmon eggs from 0 to 70 ATUs.

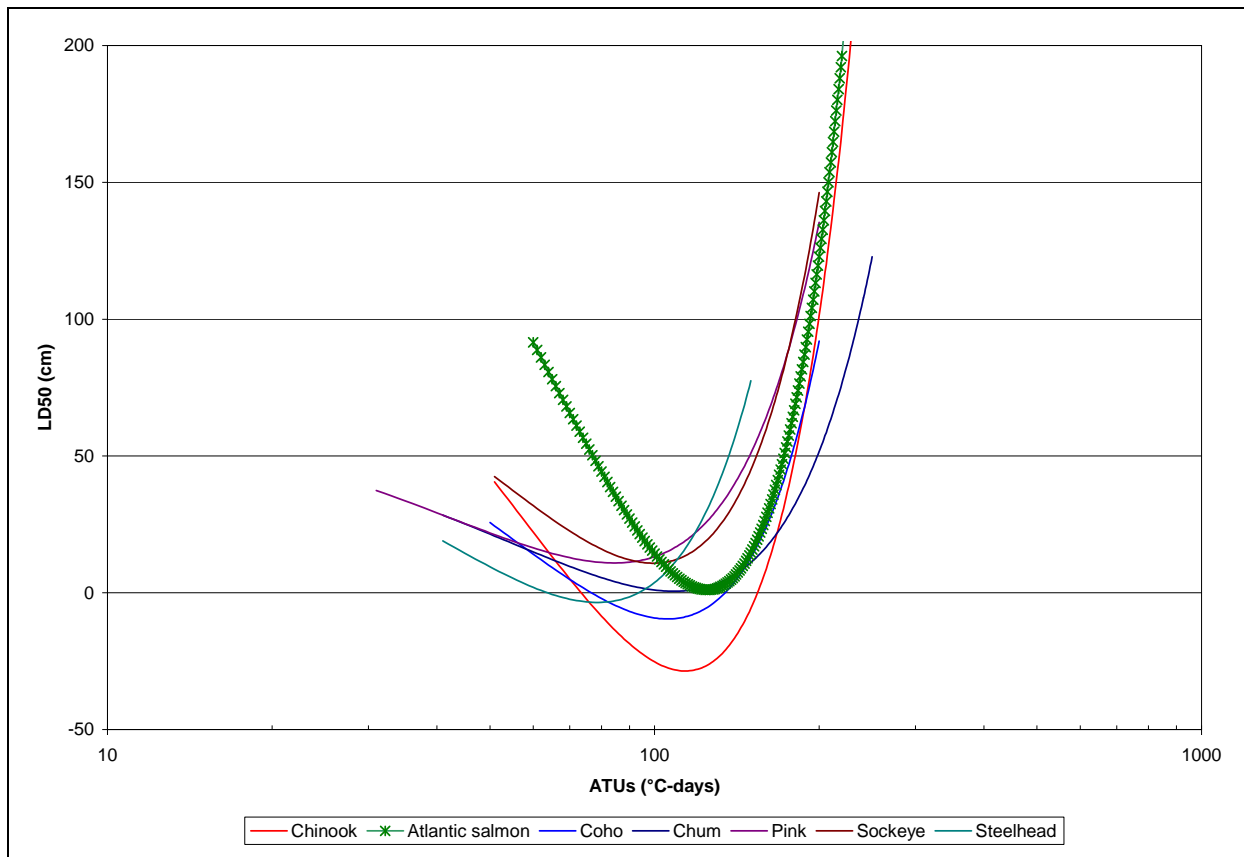

**Figure 3-9.** Predict LD50 parabolic curves for salmon 30 to 250 ATUs.

The minima (i.e. point of maximum egg shock sensitivity) were determined for Pacific and Atlantic salmon eggs (Table 3-4) from the parabolic equations (Table 3-3).

**Table 3-4.** Minimum LD50s (cm) for salmon eggs. Note: negative values for chinook, coho, and steelhead indicate that these species are extremely sensitive at this time of development.

Species	Minimum LD50 (cm)	ATUs (C°-days)
Chinook	-28.60	113.84
Chum	0.54	108.53
Coho	-9.57	105.61
Pink	10.88	84.35
Sockeye	10.79	99.58
Steelhead	-3.53	78.62
Atlantic salmon	5.49	123.99

A comparison of minimum LD10 velocities (i.e. the most shock-sensitive stage determined from LD10 and calculated in cm/sec) for Pacific salmon eggs (Jensen 2003) and Atlantic salmon eggs is shown in Table 3-5.

**Table 3-5.** Minimum LD10 velocity (cm/sec) for Pacific and Atlantic salmon eggs.

Species	Minimum LD10 Velocity (cm/sec)	ATUs (C°-days)
Chinook	14.6	110.8
Chum	41.6	99.8
Coho	23.1	94.7
Pink	62.3	87.8
Sockeye	83.8	90.6
Steelhead	33.2	78.3
Atlantic salmon	20.8	128.0

From Table 3-5, it is apparent that Atlantic salmon are the second most sensitive species tested. Yet this still is 16 times the peak particle velocity of 1.3 cm/sec recommended by Wright and Hopky (1998) as a safe criterion for seismic shock.

In summary, Atlantic salmon egg shock sensitivity falls within the levels reported for Pacific salmon eggs (Jensen and Alderdice 1983 and 1989, Jensen 2003). Un-activated Atlantic salmon eggs are the third most sensitive of those species tested (Table 3-2 and Fig. 3-7). During the early phase of embryonic development (i.e. 0 to 60 ATUs), Atlantic salmon eggs appear to be more resistant to shock than most other salmon eggs tested (Table 3-3, Fig. 3-8). Finally, during the most sensitive period of development (i.e. from 70 to 200 ATUs) Atlantic salmon eggs exhibited the second highest shock sensitivity with a minimum LD10 velocity value of 20.9 cm/sec (Table 3-5).

### **3.6 Acknowledgements**

Funding for this project was made available through collaboration with Fisheries and Oceans Canada, Pan Fish Canada Ltd., and Stolt Sea Farm Ltd. The authors would like to thank the staff at the Rosewall Creek for their assistance in setting up and maintaining the experiments. Also, thanks go to the Pan Fish Canada staff involved in obtaining and transporting the Atlantic salmon gametes used in these tests.

### **3.7 References**

- Jensen, J.O.T., and Alderdice, D.F. 1983. Changes in mechanical shock sensitivity of coho salmon (*Oncorhynchus kisutch*) eggs during incubation. *Aquaculture* 32: 303-312.
- Jensen, J.O.T., and Alderdice, D.F. 1989. Comparison of mechanical shock sensitivity of eggs of five Pacific salmon (*Oncorhynchus*) species and steelhead trout (*Salmo gairdneri*). *Aquaculture* 78: 163-181.
- Jensen, J.O.T. 2003. New mechanical shock sensitivity units in support of criteria for protection of salmonid eggs from blasting or seismic disturbance. *Can. Tech. Rep. Fish. Aquat. Sci.* 2452: 18 p.

Wright, D.G., and Hopky, G.E. 1998. Guidelines for the use of explosives in or near Canadian fisheries waters. Can. Tech. Rep. Fish. Aquat Sci. 2107: iv + 34p.

## 4 CHANGES IN SALMONID EGG SURVIVAL AFTER EXPOSURE TO MECHANICAL SHOCK AND TO VARIOUS CONCENTRATIONS OF IODINE

W.E. McLean\*, 675 Hornet Way Comox, British Columbia, V9M 0A2.

J.O.T. Jensen, T. Sweeten and W. Damon, Fisheries and Oceans Canada, Science Branch, Pacific Biological Station, Nanaimo, BC V9T6N7. Email: [Ted.Sweeten@dfo-mpo.gc.ca](mailto:Ted.Sweeten@dfo-mpo.gc.ca).

J. Lawrie and L. Beile, Stolt Sea Farm Inc. 1761 Redwood St Campbell River, BC V9W 3K7.

M. Lawrie, Pan Fish Canada Ltd. 124-1334 Island Highway, Campbell River, BC V9W 8C9.

(\*denotes first author)

### 4.1 Abstract

Small batches of eggs from Atlantic salmon (*Salmo salar*), chinook (*Oncorhynchus tshawytscha*) and steelhead (*Oncorhynchus mykiss*) were mechanically shocked and subsequently exposed to different iodine concentrations. The test was designed to simulate stressors experienced by eggs during iodophor treatments in production-hatcheries. Mortality was assessed during incubation and lethal drop heights causing 50% and 10% mortality (i.e. LD50 and LD10) were calculated at each iodine concentration. Another issue regarding iodine usage was also addressed; loss of iodine during large-scale treatments can allow pathogens to survive. To investigate this, iodine was measured during a typical disinfection procedure. In spite of a significant loss of iodine after 10 minutes (44%), the treatment was judged to be effective.

### 4.2 Introduction

Iodophors are widely used in fish culture to disinfect eggs. The active ingredient, organically bound iodine (PVP-I), has the same broad spectrum properties as elemental iodine but is relatively non-toxic to fish eggs (Nelson 1974). For this reason it is sometimes called “tamed iodine”.

In the industry, a wide range of treatment concentrations (50 to 300 mg/L) and exposure times (10 to 60 minutes) are used (Chapman and Rogers 1992). Also iodophors are commonly applied one or more times between egg fertilization and the late-eyed stage. Eggs can be dipped into prepared solutions or iodophor can be pumped to the incubators.

Treatment standardization is difficult because of two site-specific factors. Firstly, iodine is rapidly consumed by organic material so the concentration at the surface of the egg is affected by background water quality (Jensen et al. 1996) and by egg handling procedures (Chapman and Rogers 1992). Secondly, the frequency and timing of treatments depends on the nature of the hatchery program. For example one of the most common

applications is to protect a facility from diseases carried by imported eggs. In this case eggs must be disinfected before they are placed in incubators or come in contact with the hatchery water supply. This often results in the difficult task of treating and handling newly fertilized eggs. Treatment procedures that require handling of eggs in the hours following fertilization can have unexpectedly negative effects due to mechanical shock (Jensen et al. 1981). In our tests, eggs were subjected to double stresses of mechanical shock and iodophor exposure at this critical stage of development. This problem is the focus of the present study.

Loss of iodine during egg treatments is another problem addressed in this study. In vitro studies have shown that a concentration of 25-35 mg/L is required for 5 minutes to kill most common viral, bacterial and fungal pathogens (Amend and Pietsch 1972; Ross and Smith 1972; Desautels and MacKelvie 1975). In a hatchery, exposure at the surface of the egg must exceed these levels to be effective. Iodine concentrations were measured during a typical iodophor treatment in a production hatchery to assess the actual exposure of the eggs.

### **4.3 Methods**

Trials were carried out at the Big Qualicum, Rosewall Creek and Puntledge hatcheries operated by Fisheries and Oceans Canada. Tests were performed over a number of years on chinook (*Oncorhynchus tshawytscha*), steelhead (*Oncorhynchus mykiss*) and Atlantic salmon (*Salmo salar*) eggs.

Iodophors were supplied by Argent Chemicals Ltd. (Argentyne) and by Syndel Ltd. (Ovadine). Both chemicals are buffered and have 1% available iodine (10,000 ppm). Treatment solutions were prepared by dilution to get the desired concentration and then checked by titration with standard sodium thiosulfate. All concentrations are reported in mg/L of available iodine.

Fertilized eggs were subjected to a standardized mechanical shock using an apparatus developed by Jensen and Alderdice (1983, 1989). To deliver a standard shock, about 30 eggs are gently transferred to a petri dish and water is carefully decanted. The petri dish is then fixed to a steel holder that is free to slide on a vertical track from a fixed height. A trigger releases the egg holder so that it free-falls to strike the base of the apparatus. The shock is reproducible and its magnitude is a function of the height of the drop.

To measure the effects of shock, samples of eggs were dropped from heights of 0, 20, 40, 60, 80 and 100 cm. At least 3 replicates were tested at each drop height. After the shock, eggs were gently poured from the petri dishes to individual cells of a divided Heath tray containing water. Heath trays are the standard vertical-flow incubation system used in many federal government hatcheries. The dividers consist of a 20 cell Plexiglas frame with fly screen bottom that fits snugly into the Heath tray. Performing this series of shocks took approximately 12 minutes. When a series was complete the divider was lifted out of the Heath tray containing water and transferred to a Heath tray containing an

iodophor solution of known concentration. After 10 minutes exposure to iodine, the water flow to the tray was started and the iodine was quickly diluted.

To quantify the combined effect of mechanical shock and iodine exposure, the lethal drop-height to cause 50 % mortality (LD50) was calculated for each iodine concentration. A high LD50 value means that the eggs are resistant to mechanical shock. A decrease in the LD50 as a function of iodine concentration means that the eggs are more sensitive to mechanical shock if it is immediately followed by exposure to iodine. Probit analysis (Jensen and Alderdice 1983) was used to calculate LD50, LD10 and 95% confidence intervals.

#### **4.3.1 Big Qualicum: 1983/84**

In 1983 chinook eggs were tested 2.75 hours after fertilization (i.e. after the start of development). Eggs were shocked (at drop-heights of 0, 20, 40, 60, 80 and 100 cm) and then exposed to a 0 mg/L solution, 84 mg/L (Argentyne) and 122 mg/L (Ovadine) for 10 minutes. Live and dead eggs were accurately counted at the eyed stage (42 days post fertilization) and mortality rates were assessed.

In 1984 a similar test was performed with steelhead eggs (2.75 hours after fertilization). Eggs were shocked at the standard drop-heights (3 replicates) and then exposed to Ovadine solutions with available iodine concentrations of 0, 105, 214, 325 and 438 mg/L. Egg mortality was assessed at the eyed stage.

#### **4.3.2 Rosewall Creek: 2002**

Exploratory tests were performed with Atlantic salmon eggs at Rosewall Creek in 2002. Eggs were supplied by Pan Fish Canada Ltd. One hour after fertilization, eggs were subjected to 0 and 20 cm drops and then exposed to Ovadine concentrations of 0 and 100 mg/L for 10 minutes. Three replicates were tested for each treatment combination. Iodine concentrations were not measured in 2002 – values were calculated from dilution of stock (i.e. nominal values).

Another test was performed in 2002 where the order of the stressors was changed -- eggs were first exposed to iodine (0 and 100 mg/L) and then shocked (drop heights of 0 and 20 cm). In this test a procedure called “zero time disinfection” was used. Milt was added to the eggs and after 2 minutes of contact time the mixture was transferred to Ovadine (100 mg/L). In this procedure, egg activation (and the beginning of development) occurs in the Ovadine solution instead of water. After 10 minutes eggs were removed and shocked (0 and 20 cm).

#### **4.3.3 Rosewall Creek: 2003**

A full series of tests were performed on Atlantic salmon and chinook eggs in 2003. Atlantic salmon eggs were supplied by Pan Fish Canada Ltd. while the chinook eggs came from Big Qualicum Hatchery. Tests were similar to the steelhead treatments at Big

Qualicum in 1984 except that testing began 1 hour after fertilization. Eggs were shocked at the standard series of drop-heights and then exposed for 10 minutes to iodine concentrations of 0, 106, 208, 312 and 421 mg/L for Atlantic salmon and 0, 87, 185, 285 and 397 mg/L for chinook. Five replicates were performed for each control group (0 cm drop). Egg mortality was assessed until after hatch. Atlantic salmon eggs were fertilized on Nov 18, 2003 and mortality was assessed until Feb 18, 2004 (779 °C days). Chinook eggs were fertilized on Oct 24, 2003 and the final assessment of mortality was made on Dec 29, 2003 (566 °C days). The average incubation temperature was 8.5 °C.

#### **4.3.4 Puntledge Hatchery: 2003**

The iodine concentration experienced by the eggs during a production scale iodophor treatment was measured at Puntledge Hatchery on October 21. The standard treatment used at this hatchery is “zero-time disinfection” for 10 minutes at a nominal iodine concentration of 100 mg/L. To measure the actual exposure the following procedure was followed. Trays in a Heath stack were pulled forward out of the water flow, thoroughly drained and then filled to the brim with Ovadine solution (nominal 100 mg/L). Trays were loaded with eggs in sequence starting with the second tray. Batches of 8500 chinook eggs were mixed with 15 mL of milt and allowed to stand for 2 minutes. The egg milt mixture was not rinsed but poured directly into a tray containing Ovadine. With several minutes between each tray loading (to allow sampling), this procedure was followed until all seven trays were loaded. After a treatment time of 10 minutes, samples were slowly siphoned from within the egg mass for titration. Samples were taken from tray 1 (no eggs), tray 2, tray 5 and tray 8. For this test, the egg treatment was extended to 20 minutes and further samples were taken. After the final sample, trays were eased back into the stack and the iodine was quickly diluted by the water flow (15 L/min).

Loss of iodine in tray 1 showed the effects of background water quality, whereas losses in the other trays show the combined effect of excess milt, ovarian fluid and organic contamination from the eggs and water. A further test was performed to measure the losses due to excess milt.

## 4.4 Results

Egg mortality is shown for each replicate for Big Qualicum Chinook 1983, Big Qualicum Steelhead 1984 (Table 4-1) and for Rosewall Atlantic Salmon 2003 and Rosewall Chinook 2003 (Table 4-2). In these tests, mechanical shock (drop heights cm) was followed by exposure to iodine (available iodine mg/L).

**Table 4-1.** Mortality (%) for Big Qualicum chinook (1983) and steelhead (1984) eggs subjected to mechanical shock (Drop Height; cm) followed by exposure to iodine (mg/L). Each treatment has 3 replicates.

Big Qualicum Chinook 1983					
	Iodine concentration mg/L				
Drop Height cm	0 mg/L	84 mg/L	122 mg/L		
0 cm	0.00	0.00	4.00		
	7.69	0.00	0.00		
	0.00	0.00	0.00		
20 cm	29.17	34.62	59.09		
	16.00	77.27	60.00		
	26.09	34.78	53.57		
40 cm	52.00	79.17	76.92		
	74.07	45.83	73.91		
	80.77	68.18	77.27		
60 cm	30.77	92.31	61.54		
	64.29	54.17	95.65		
	93.10	88.89	92.00		
80 cm	77.78	95.83	91.30		
	78.57	84.62	95.83		
	82.14	100.00	96.00		
100 cm	92.00	100.00	96.00		
	63.64	96.00	100.00		
	73.91	85.71	100.00		
Big Qualicum Steelhead 1984					
	Iodine Concentration mg/L				
Drop Height cm	0 mg/L	105 mg/L	214 mg/L	325 mg/L	438 mg/L
0 cm	11.36	7.14	0.00	12.50	14.29
	8.57	6.67	10.81	4.76	33.33
	6.06	2.78	2.56	6.25	25.00
20 cm	18.60	13.79	18.75	43.75	42.86
	57.89	21.88	36.11	18.60	58.33
	26.32	11.76	30.56	31.43	79.31
40 cm	18.60	17.24	40.00	44.74	71.05
	57.89	27.78	48.65	33.33	51.43
	26.32	47.50	40.74	54.29	83.87
60 cm	31.91	82.86	28.57	93.48	72.41
	40.00	50.00	51.02	51.61	70.45
	58.82	65.79	60.00	65.63	68.42
80 cm	52.94	60.53	63.64	67.50	96.88
	80.65	70.00	84.62	70.00	65.52
	82.86	75.51	92.31	85.37	90.32
100 cm	89.13	75.86	92.68	85.29	97.37
	38.71	82.76	92.86	90.63	93.75
	100.00	88.37	76.32	84.21	85.71

**Table 4-2.** Mortality (%) for Atlantic salmon and chinook eggs subjected to mechanical shock (Drop Height, cm) followed by exposure to iodine (mg/L) at Rosewall Creek in 2003. Control treatments have 5 replicates and drop treatments have 3 replicates.

Rosewall Atlantic Salmon 2003					
	Iodine Concentration mg/L				
Drop Height cm	0 mg/L	106 mg/L	208 mg/L	312 mg/L	421 mg/L
0 cm	6.90	13.16	19.44	27.27	15.91
	30.30	19.51	13.16	13.95	20.51
	13.33	16.28	16.28	15.91	21.05
	8.57	22.50	27.50	19.57	11.90
	11.11	10.00	22.50	20.00	17.14
	12.50	30.56	39.47	15.63	36.59
20 cm	20.59	30.56	27.50	44.12	21.95
	27.59	18.42	18.60	19.05	35.71
	44.74	20.00	18.92	53.85	43.24
40 cm	46.88	20.59	42.50	44.44	46.15
	25.00	47.06	36.59	42.86	43.24
	27.27	50.00	68.57	46.15	50.00
60 cm	42.42	52.78	34.29	69.44	60.00
	55.26	44.74	42.11	45.95	79.07
	61.90	75.68	71.79	48.72	69.05
80 cm	70.45	65.71	58.82	87.18	56.82
	54.55	73.68	50.00	50.00	64.29
	58.97	77.78	81.08	92.11	88.10
100 cm	61.54	78.57	82.50	92.50	75.00
	73.68	63.41	87.18	68.29	81.08
Rosewall Chinook 2003					
	Iodine Concentration mg/L				
Drop Height cm	0 mg/L	87 mg/L	185 mg/L	285 mg/L	397 mg/L
0 cm	6.45	10.71	0.00	0.00	0.00
	15.63	3.33	5.71	6.45	0.00
	13.79	0.00	0.00	0.00	3.13
	3.33	5.88	3.03	10.71	9.09
	3.45	0.00	0.00	3.03	3.23
	35.71	31.03	45.16	19.35	24.14
20 cm	35.00	61.29	28.57	67.74	60.61
	35.71	26.67	41.38	66.67	39.39
	70.97	65.52	70.59	74.19	59.38
40 cm	56.25	58.06	65.63	70.00	65.63
	26.32	41.94	51.61	87.50	54.55
	63.33	77.42	87.50	74.07	71.88
60 cm	68.97	81.25	70.59	85.71	74.19
	59.38	79.41	82.76	73.33	67.74
	90.91	81.25	100.00	86.67	87.88
80 cm	67.65	71.88	84.38	90.00	90.63
	64.52	70.00	100.00	74.19	88.24
	93.94	90.91	92.31	93.94	87.50
100 cm	74.19	93.55	87.50	87.10	81.25
	90.63	91.18	96.88	93.33	100.00

LD50 values were calculated in order to quantify the combined effect of drop height and iodine (Table 4-3).

**Table 4-3.** LD50 (drop in cm to cause 50% mortality) and 95% confidence limits. LD10 (drop in cm to cause 10% mortality) is also shown.

Test	Iodine mg/L	LD50 cm	Lower	Upper	LD10 cm
			LD50 95% Confidence Limits		
<b>Big Qualicum Chinook 1983</b>					
	0	36.3	31.2	42.2	8.8
	84	23.4	20.2	27.1	6.4
	122	18.1	15.4	21.2	4.7
<b>Big Qualicum Steelhead 1984</b>					
	0	53.3	46.2	61.5	11.5
	105	53.1	48.4	58.3	21.1
	214	46.3	41.6	51.5	14.5
	325	41.4	36.9	46.4	12.4
	438	28.8	23.5	35.3	5.5
<b>Rosewall Atlantic Salmon 2003</b>					
	0	76.8	66.2	89.0	22.1
	106	68.7	61.7	76.4	27.5
	208	71.1	64.1	78.9	33.4
	312	62.5	55.9	70.4	22.5
	421	56.7	49.9	64.4	16.0
<b>Rosewall Chinook 2003</b>					
	0	41.2	35.8	47.5	10.3
	87	30.9	26.9	35.4	7.8
	185	28.0	25.0	31.3	9.5
	285	19.1	16.0	22.9	3.4
	397	28.6	25.0	32.7	7.4

These values are plotted against iodine concentration for each group in Figure 4-1. Intercepts (b), slopes (m), and  $R^2$  values for the least square regression lines are presented in Table 4-4;  $LD50 = b + m \cdot \text{Iodine}$ . All groups showed an increasing sensitivity to mechanical shock as iodine concentrations increased (negative slopes). Except for the Chinook 2003 group, slopes were statistically significant ( $P < 0.05$ ).

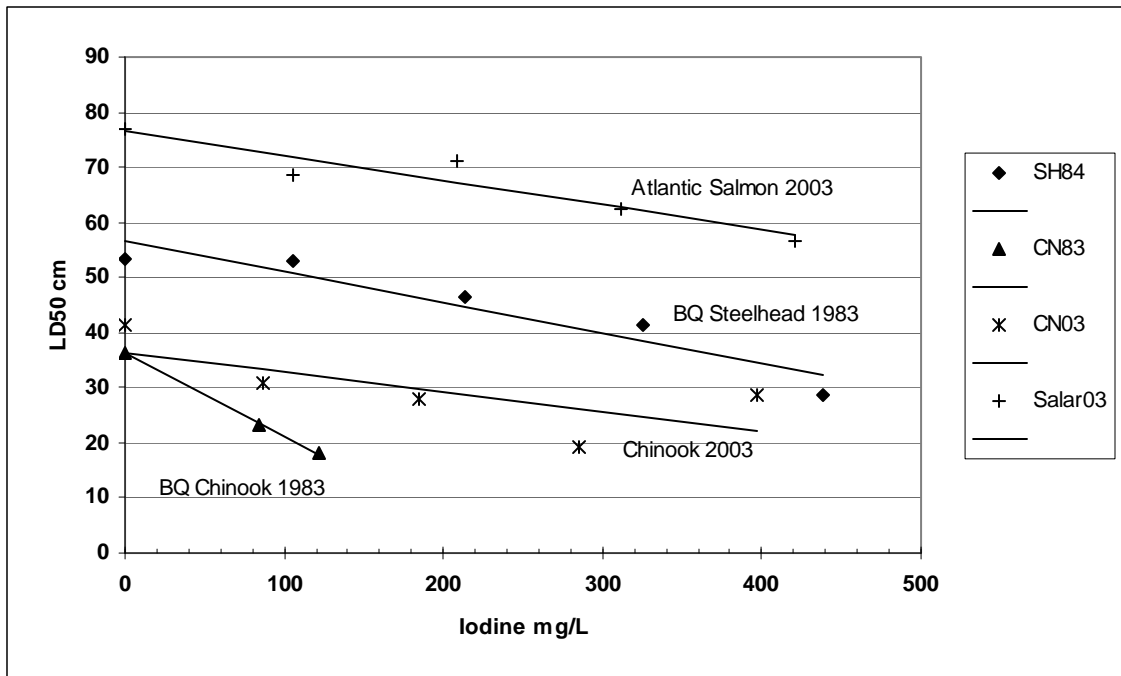

**Figure 4-1.** Lethal drop (cm) to kill 50% (LD50) of eggs versus iodine concentration mg/L for 4 groups of eggs (SH (steelhead) 1984, CN (chinook) 1983 and 2003, Salar (Atlantic salmon) 2003).

In 2003 eggs were shocked 1 hour after fertilization while in 1983/84 eggs were shocked 2.75 hours post-fertilization.

**Table 4-4.** Linear regression lines for LD50 (cm) versus iodine concentration (mg/L). Slope, intercept,  $R^2$  and the number of observations (N) are shown for each group and for pooled chinook data (1983 and 2003).

Groups	Intercept	Slope	$R^2$	N
Big Qualicum CN 1983	36.21	- 0.1500	0.9996	3
Big Qualicum SH 1984	56.62	- 0.0556	0.9054	5
Salar 2003	76.44	- 0.0444	0.8932	5
CN 2003	36.41	- 0.0360	0.5078	5
CN Pooled	32.30	- 0.0288	0.2406	8

Analysis of variance (ANOVA) tables are shown for each experiment in Table 4-5. The 2003 results were treated as 2 factor experiments with unequal replicates per subclass (Sokal and Rohlf 1981). Significant effects (at  $P < 0.05$ ) and the “least significant difference” are also shown.

**Table 4-5.** Analysis of variance for experiments. Mean Squares, degrees of freedom, significant F values, and the “least significant difference” are shown for P < 0.05.

Chinook Shock/Iodine 1983				
Source of Variation	df	MeanSq.	F ratio	
Drop Height cm	5	10357	56.18	significant
Iodine	2	1223	6.63	significant
Interaction	10	154	0.83	not significant
Within (error)	36	184		
Least Sig. Difference			22.4	
Steelhead Shock/Iodine 1984				
Source of Variation	df	MS	F ratio	
Drop Height cm	5	11533	61.72	significant
Iodine	4	1483	7.94	significant
Interaction	20	184	0.98	not significant
Within (error)	60	187		
Least Sig. Difference			22.3	
Atlantic Salmon Zero-Time 2002				
Source of Variation	df	MS	F ratio	
Drop Height cm	1	0.9	0.02	not significant
Iodine	1	3.8	0.08	not significant
Interaction	1	13.6	0.28	not significant
Within (error)	8	47.9		
Least Sig. Difference			13.0	
Atlantic Salmon 1 Hour Iodine/Shock 2002				
Source of Variation	df	MS	F ratio	
Drop Height cm	1	189.8	3.46	not significant
Iodine	1	22.8	0.42	not significant
Interaction	1	12.4	0.23	not significant
Within (error)	8	54.9		
Least Sig. Difference			14.0	
Chinook Shock/Iodine 2003				
Source of Variation	df	MS	F ratio	
Drop Height cm	5	20773.2	214.09	significant
Iodine	4	254.3	2.62	significant
Interaction	20	117.6	1.21	not significant
Within (error)	70	97.0		
Least Sig. Difference			16.1	
Atlantic Salmon Shock/Iodine 2003				
Source of Variation	df	MS	F ratio	
Drop Height cm	5	9235.4	92.12	significant
Iodine	4	266.5	2.66	significant
Interaction	20	87.8	0.88	not significant
Within (error)	70	100.3		
Least Sig. Difference			16.4	

In 2002 two preliminary tests were performed with Atlantic Salmon at Rosewall Creek. In the first test eggs were fertilized and activated in 100 mg/L iodine (zero-time disinfection) and then shocked at 0 and 20 cm drop-heights (Table 4-6).

**Table 4-6.** Mortality (%) for preliminary tests performed at Rosewall hatchery in 2002 with Atlantic salmon eggs. Only 2 drop heights and 2 iodine concentrations were used and eggs were tested at fertilization and 1 hour post-fertilization.

Zero-Time Disinfection followed by shock			Shock 1 hr post fertilization followed by Ovadine		
Drop Heights cm	0 (I <sub>2</sub> mg/L)	100(I <sub>2</sub> mg/L)	Drop Heights cm	0 (I <sub>2</sub> mg/L)	100(I <sub>2</sub> mg/L)
0 cm	12.82	14.63	0 cm	4.76	8.82
	21.21	17.02		18.18	15.63
	7.32	19.44		7.89	8.57
20 cm	21.62	15.38	20 cm	21.62	12.12
	21.62	9.52		8.57	18.42
	2.86	18.18		18.42	32.43

Analysis of variance showed that at these conservative levels of stress, there was no significant effect ( $P < 0.05$ , Table 4-5) on mortality from either drop height or iodine. Furthermore, egg fertilization in 100 mg/L iodine solution was similar to fertilization in water (i.e. 0 mg/L iodine). In the second preliminary test performed in 2002, eggs were shocked at 1 hour post-fertilization and then exposed to iodine (Table 4-6). Neither drop-height (20 cm) nor iodine (100 mg/L) had a significant effect on mortality (at  $P < 0.05$ ).

The loss of iodine during production scale “zero-time” disinfection procedures was measured at Puntledge Hatchery in 2003. Milt was mixed with eggs (15 mL per 8500 chinook eggs) and this mixture (not rinsed) was poured into Heath Trays containing 92 mg/L available iodine. Over a 10 minute exposure the iodine dropped to 52 mg/L (44 % loss) and after 20 minutes dropped to 48 mg/L (48% loss). There was 0 % loss in a tray containing only water (no eggs).

The effect of excess sperm on iodine consumption was measured in a separate test. Milt at concentrations of 1.32, 2.68 and 4.00 mL per liter of Ovadine solution were allowed 10 minutes of contact. The iodine consumed ( $Y$  mg/L) was related to the milt concentration ( $X$  mL/L) by:  $Y = 7.2 + 3.3 * X$ . Since a batch of eggs was fertilized with 15 mL of milt and placed in a Heath Tray containing approximately 10 L of Ovadine, the milt concentration was 1.5 mL/L and the predicted iodine loss due to excess sperm was 12 mg/L ( $7.2 + 1.5 * 3.3$ ).

## 4.5 Discussion

In the mechanical shock/iodine experiments all groups showed increased sensitivity at higher iodine concentrations. Thus LD50 decreased as iodine increased (Figure 4-1). Although a statistically significant increase in mortality was not demonstrated at the commonly used level of 100 mg/L, this trend emphasizes the danger of handling (netting, pouring etc.) newly fertilized eggs just prior to iodine treatment.

Zero-time disinfection avoided this combined stress of handling and iodine because eggs were activated in iodine solution and underwent no further movement. The preliminary test performed in 2002 showed that there was no significant difference in mortality for Atlantic salmon eggs activated in water and 100 mg/L Iodine solution.

It should be cautioned that our small-scale tests do not guarantee that a procedure is safe on the production scale. The sample size used in our tests was necessarily small (~ 30 eggs per replicate) and therefore subtle delayed effects (e.g. deformities, problems at hatch or ponding etc.) could not be detected. Also variability within replicates (error) was quite large and so real effects might simply be undetected. This “error” is termed the “within mean square” in ANOVA and along with the “least significant difference” is shown in Table 4-5 for each experiment. This value shows that mortality rates must be 15 or 20 % higher than the control before they are judged significant. Thus small effects are undetectable. Furthermore it must be kept in mind that effects having a minor impact in a small scale experiment with low egg density can be amplified many times in a production setting. These considerations lend importance to the trends observed in Figure 4-1.

In the 2003 tests 5 replicates were performed at 0 cm drop height (controls) for each iodine concentration (Table 4-1). Comparison between the 25 control groups for chinook and Atlantic salmon shows that mortality was 4 times higher in Atlantic salmon (4.3 % vs. 17.4%). This difference was significant at  $P < 0.01$  and may indicate a problem with initial egg quality of the Atlantic salmon.

During “zero-time” disinfection at Puntledge Hatchery iodine levels within the egg mass dropped to 52 mg/L after 10 minutes (44 % loss) and dropped to 48 mg/L after 20 minutes (48 % loss). On the day of the test (October 21) background water quality at Puntledge was good and had no effect on iodine loss. This may vary from day to day as the water quality of the Puntledge River changes. In our test, a total of 40 mg/L of iodine was consumed after 10 minutes. Excess sperm accounted for 12 mg/L (by calculation) while the difference of 28 mg/L (40 mg/L – 12 mg/L) was consumed by organic debris. In spite of these iodine losses, “zero-time” disinfection at Puntledge Hatchery on Oct 21 2003 met the minimum criteria for eliminating most common pathogens (25-35 mg/L for 5 min). More tests are required to assess the effectiveness of this disinfection procedure.

## **4.6 Acknowledgements**

Funding for this project was made available through collaboration with Fisheries and Oceans Canada, Pan Fish Canada Ltd., and Stolt Sea Farm Ltd. The authors would like to thank the staff at the Big Qualicum, Rosewall and Puntledge Hatcheries for their assistance in setting up and maintaining the experiments. Also, thanks go to the Pan Fish Canada staff involved in obtaining and transporting the Atlantic salmon gametes used in these tests.

## 4.7 References

- Amend, D.F., and Pietsch, J.P. 1972. Virucidal activity of two iodophors to salmonid viruses. *J. Fish. Res. Board Can.* 29: 61-66.
- Chapman, P.F., and Rogers, R.W. 1992. Decline in iodine during water hardening of salmonid eggs and methods to reduce this effect. *The Progressive Fish-Culturist* 54: 81-87.
- Desautels, D., and MacKelvie, R.M. 1975. Practical aspects of survival and destruction of infectious pancreatic necrosis virus. *J. Fish. Res. Board Can.* 32: 523-531.
- Jensen, J.O.T., McLean, W.E., and Alderdice, D.F. 1981. Effects of accessory factors on survival of newly fertilized eggs treated with an antibiotic. *Aquaculture* 23: 295-307.
- Jensen, J.O.T., and Alderdice, D.F. 1983. Changes in mechanical shock sensitivity of coho salmon (*Oncorhynchus kisutch*) eggs during incubation. *Aquaculture* 32: 303-312.
- Jensen, J.O.T., and Alderdice, D.F. 1989. Comparison of mechanical shock sensitivity of eggs of five Pacific salmon (*Oncorhynchus*) species and steelhead trout (*Salmo gairdneri*). *Aquaculture* 78: 163-181.
- Jensen, J.O.T., McLean, W.E., Damon, W., Sweeten, T., and O'Dowd, D. 1996. Elemental iodine as a fungicide for Pacific salmon. *Bull. Aquacult. Assoc. Canada.* 96-1.
- Nelson, C. 1974. A review of the literature on the use of Betadine in Fisheries. Bureau of Sport Fisheries and Wildlife, PB-235 443. Distributed by National Technical Information Service. U.S. Department of Commerce, Springfield Va. p.48.
- Ross, A.J., and Smith, C.A. 1972. Effect of two iodophors on bacterial and fungal fish pathogens. *J. Fish. Res. Board Can.* 29: 1359-1361.
- Sokal, R.R., and Rohlf, F.J. 1981. *Biometry, Second Edition.* W.H. Freeman and Company. New York. p. 859.

## 5 ATLANTIC SALMON (*SALMO SALAR*) EGG AND LARVAL DEVELOPMENT AND MORTALITY RATES AT TEMPERATURES RANGING FROM 4 TO 14 °C.

J.O.T. Jensen\*, W. Damon, and T. Sweeten. Fisheries and Oceans Canada, Science Branch, Pacific Biological Station, Nanaimo, BC V9T6N7.

Email: [Ted.Sweeten@dfo-mpo.gc.ca](mailto:Ted.Sweeten@dfo-mpo.gc.ca)

K. Davis, 1573 Madrona Drive, Nanoose Bay, BC V9P9C9

W.E. McLean, 675 Hornet Way Comox, British Columbia, V9M 0A2.

J. Lawrie and L. Beile, Stolt Sea Farm Inc. 1761 Redwood St., Campbell River, BC V9W 3K7.

M. Lawrie, Pan Fish Canada Ltd. 124-1334 Island Highway, Campbell River, BC V9W 8C9.

(\*denotes first author)

### 5.1 Abstract

Atlantic salmon (*Salmo salar*) eggs were incubated at 4, 6, 8, 10, 12, and 14 °C from fertilization to complete yolk absorption. Results from the first of two years' work are presented in this paper, with the understanding that models and conclusions may change after analyses of results from the second year. Provisional models for egg to fry mortality

$$Y(\text{mortality \%}) = 189.17 - 74.83X(^{\circ}\text{C}) + 9.09X(^{\circ}\text{C})^2 - 0.30X(^{\circ}\text{C})^3; \quad r^2 = 0.959$$

and time to 50% hatch

$$Y(\text{days to 50\% hatch}) = 27475.88 / (X(^{\circ}\text{C}) + 6.8616)^{2.2718}; \quad r^2 = 0.996$$

predicted minimum mortality at 5.7 °C and days to hatch ranging from 122 to 35 days, at 4 and 12 °C, respectively. Samples of eggs and larvae were preserved in 10% formalin over various intervals during incubation, from which photo-micrographs were made of important stages of development. Embryo tissue and yolk weights were measured and utilized to model tissue growth, yolk absorption, and maximum alevin wet weight (MAWW) in relation to temperature. Provisional models for time to 10% and 0% yolk remaining (based on wet weight) follow

$$Y(\text{days to 10\% yolk}) = 306.61 \epsilon^{-0.1176X(^{\circ}\text{C})} \quad r^2 = 0.993$$

$$Y(\text{days to 0\% yolk}) = 326.79 \epsilon^{-0.1121X(^{\circ}\text{C})} \quad r^2 = 0.999$$

In addition, eyed eggs and newly hatched larvae were transferred from 8 °C to 10, 12, and 14 °C, with significant decreases in mortality compared to constant exposure to these higher temperatures. Finally, oxygen consumption measurements (i.e. Ro; mg O2 per

1000 individuals per hour) were conducted and modelled for eggs and larvae at 4 to 10 °C from 200 to 800 ATUs. To illustrate these relationships, the model with the highest  $r^2$  value was observed at 6 °C and is presented below

$$Y(\text{Ro @ 6 } ^\circ\text{C; mg O}_2 \text{ per 1000 *hr}) = 0.1916X(\text{days}) - 7.3887 \quad r^2 = 0.878$$

## **5.2 Introduction**

Many researchers have studied and reported on the influence of temperature on salmonid egg development and mortality (Billard and Jensen, 1996; Beacham and Murray, 1990; McLean et al., 1991; Velsen, 1987; Gunnes, 1979; Peterson et al., 1977). Hence, we have information about egg and larval mortality at various temperatures. However, the temperature ranges tested and knowledge about differences in sensitivity to high or low temperatures at various stages of development are limited. In particular, knowledge about high and low water temperature tolerance of Atlantic salmon eggs also needs to be improved. Furthermore, the impact of temperature on embryo development, growth, and yolk conversion needs to be studied. Hence, a comprehensive study was undertaken to incubate Atlantic salmon eggs in a series of constant temperatures. During the egg to fry period various parameters were looked at, including overall mortality, embryonic and larval development rates, oxygen consumption rates, and incidence of abnormalities.

## **5.3 Methods**

Atlantic salmon eggs (pooled sub-samples of about 500 eggs per female, from 10 females) and sperm (pooled from 10 males) were obtained from Pan Fish Canada hatchery at Rosewall Creek on Nov. 13, 2002. These gametes were transported, cooled with ice in separate containers, to the Pacific Biological Station, where they were fertilized and placed in incubation baskets (4 replicates, of about 50 eggs per replicate, per temperature-treatment; plus ~200 extra eggs in additional baskets for developmental sampling)(Fig. 5-1). Temperature baths consisted of 40-liter computer-controlled tanks of water with make-up water flows of 80 ml/min (i.e. about 3 exchanges per day). Test temperatures were set at 4, 6, 8, 10, 12, and 14 °C ( $\pm 0.1$  °C).

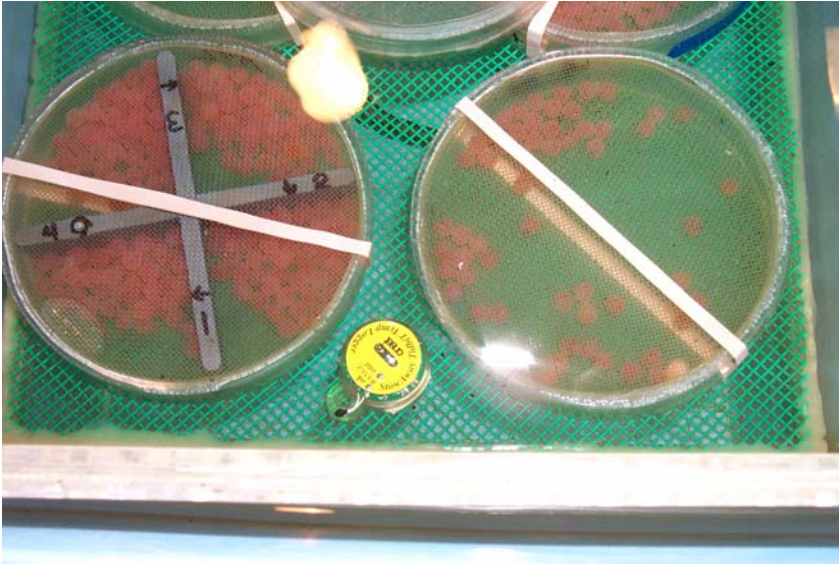

**Figure 5-1.** Baskets used for incubation. Eggs were in a single layer. One basket contained 4 replicates for mortality assessment, a second basket contained eggs used for growth rate sampling.

Two types of temperature exposures were conducted. The main experiment involved incubation of eggs from fertilization to complete yolk absorption in 6 constant temperatures of 4 to 14 °C mentioned above. Data collected from this experiment included egg to fry mortality, hatching time determination, and embryo samples for growth and abnormality determination. For growth and abnormality assessment, eggs and larvae (i.e. 5 to 10 individuals per sample) were sampled periodically from fertilization to complete yolk absorption. The samples were anesthetized in a lethal dose of MS222 and placed in 10% formalin.

The secondary experiment was set up to test impact of transferring either eggs at the eyed stage or larvae at hatch from 8 °C to 10, 12, and 14 °C. Egg to fry mortality data was collected.

Finally, oxygen consumption was measured for eggs and larvae at 4, 6, 8, and 10 °C from 200 to 800 ATUs. Modified experimental Plexiglas incubators (i.e. volume =1.5 L, flow rate 0.5 LPM, apparent velocity =310 cm/hr) were used (Fig. 5-2). Three replicate incubators, each with a single layer (i.e. an average of 129 eggs or larvae per replicate), and one control incubator (i.e. just water) were used for each oxygen consumption test. Eggs or larvae were very carefully transferred from a test incubation temperature of 4 to 10 °C, at 200, 400, 600, and 800 ATUs, to the 3 incubators, in dark conditions. The incubator lids were fastened and any air bubbles were removed. After about one hour of acclimation, the outflow from each incubator was attached to the inflow, thus creating a closed loop. Attached to each incubator was an oxygen sensor, connected to a multi-channel oxygen meter, which was in turn connected to a data-logger. Oxygen consumption was monitored and was allowed to decrease by several mg/L, after which the test was stopped and the test eggs and larvae returned to their appropriate incubation temperature to continue development until the next test interval. Oxygen consumption

rates (i.e. mg O2 per 1000 individuals per hour) were calculated for the linear portions of each oxygen consumption data set.

## 5.4 Results

Total egg to fry mortality (i.e. from fertilization to swim-up) for each of the 6 test temperatures was recorded and is illustrated in Figure 5-2. A 3rd order polynomial model was fitted to the data and used to predict an optimum temperature of 5.74 °C.

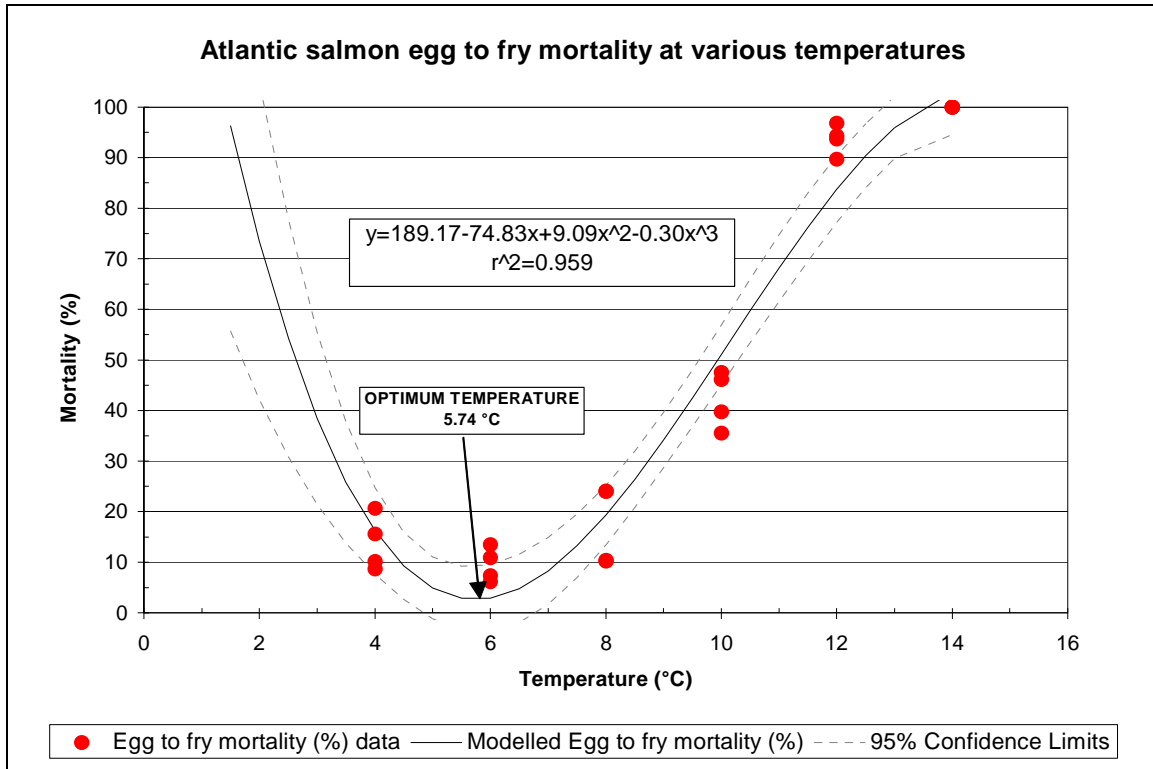

**Figure 5-2.** Atlantic salmon egg to fry mortality (%) at 4 to 14 °C.

Time to 50% hatch was determined for temperatures of 4 to 12 °C, since no eggs survived to hatch at 14 °C. The data are summarized in Table 5-1 and typical inverse relationships (i.e. modified Belehradek “BLM” and ATU models; Mclean et al., 1991) are as follows

$$Y_{\text{BLM model}}(\text{days to 50\% hatch}) = 27475.88 / (X(^{\circ}\text{C}) + 6.8616)^{2.2718}; \quad r^2 = 0.996$$

$$Y_{\text{ATU model}}(\text{days to 50\% hatch}) = 481.15 / X(^{\circ}\text{C}); \quad r^2 = 0.940$$

and is illustrated in Figure 5-3. These BLM models (days and ATUs) for time to 50% hatch show the impact of temperature, with time to hatching ranging from 36 to 121 days from 14 to 4 °C (Table 5-1). Figure 5-3 includes BLM models as well as the simpler ATU model (i.e.  $y = x/a$ ; where the constant  $a = 481.15$  ATUs). The difference in

predictions of development timing is most apparent at the lower extrapolated temperatures (i.e. 47 days at 2 °C; see Fig. 5-3).

**Table 5-1.** Time to 50% hatch, in hours, days, or ATUs, for Atlantic salmon eggs at 4 to 12 °C. Eggs were fertilized on November 13, 2002.

Temperature (°C)	Date	Time to 50% hatch (hours)	Time to 50% hatch (days)	Time to 50% hatch (ATUs; °C-days)
4	Mar 4 2003	2904	121	484
6	Feb 7 2003	2064	86	516
8	Jan 9 2003	1368	57	456
10	Dec 27 2002	1056	44	440
12	Dec 19 2002	864	36	432
14	No survivors			

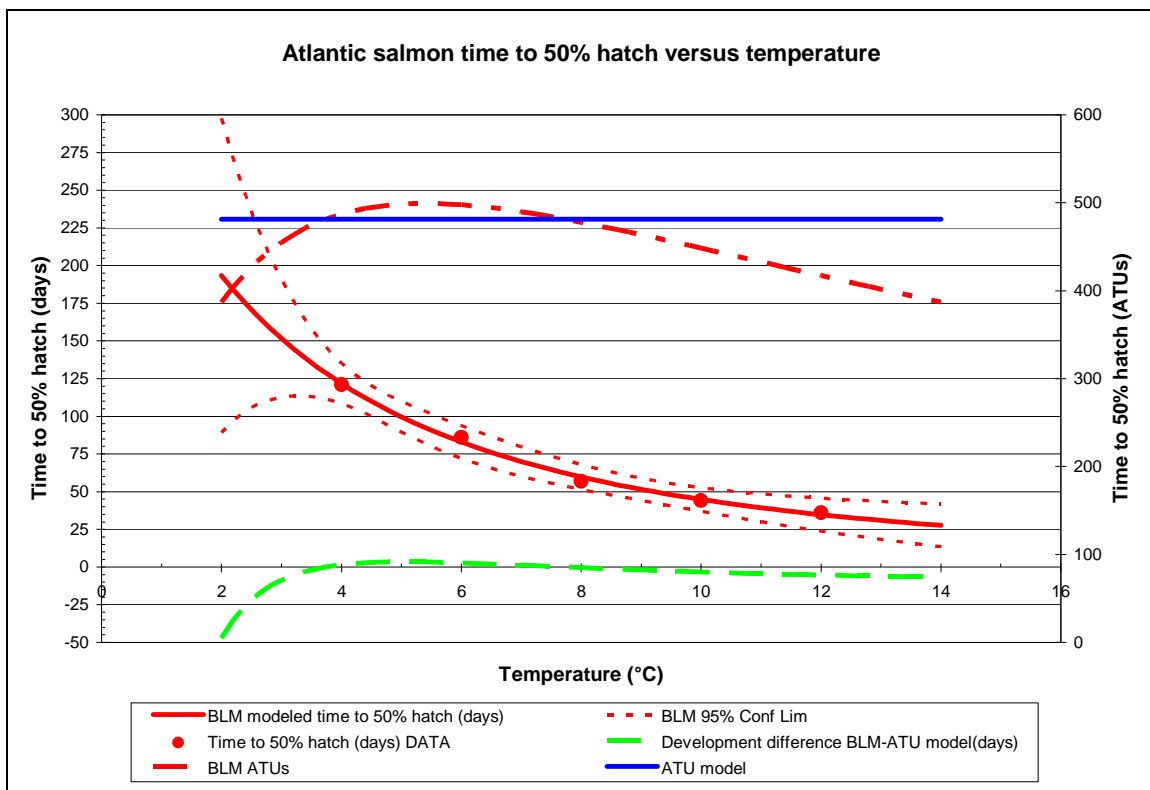

**Figure 5-3.** Atlantic salmon egg development time (red circle; days) to 50% hatch from 4 to 12 °C. The modified Belehradek model “BLM” (red solid line) with 95% confidence limits (red dashed lines) shows a typical inverse relationship. The ATU (°C-days) model (blue solid line) yielded a constant of 481.15 °C-days, while ATUs calculated from the BLM model (red long & short dashed line) were curvilinear with differences (i.e. BLM-ATU models, green dashed line) ranging up to -47 days at 2°C

Alevin wet weight (including predicted maximum alevin weight wet {MAWW}) and percent tissue and yolk weight changes, at 8 °C, are illustrated in Figure 5-4.

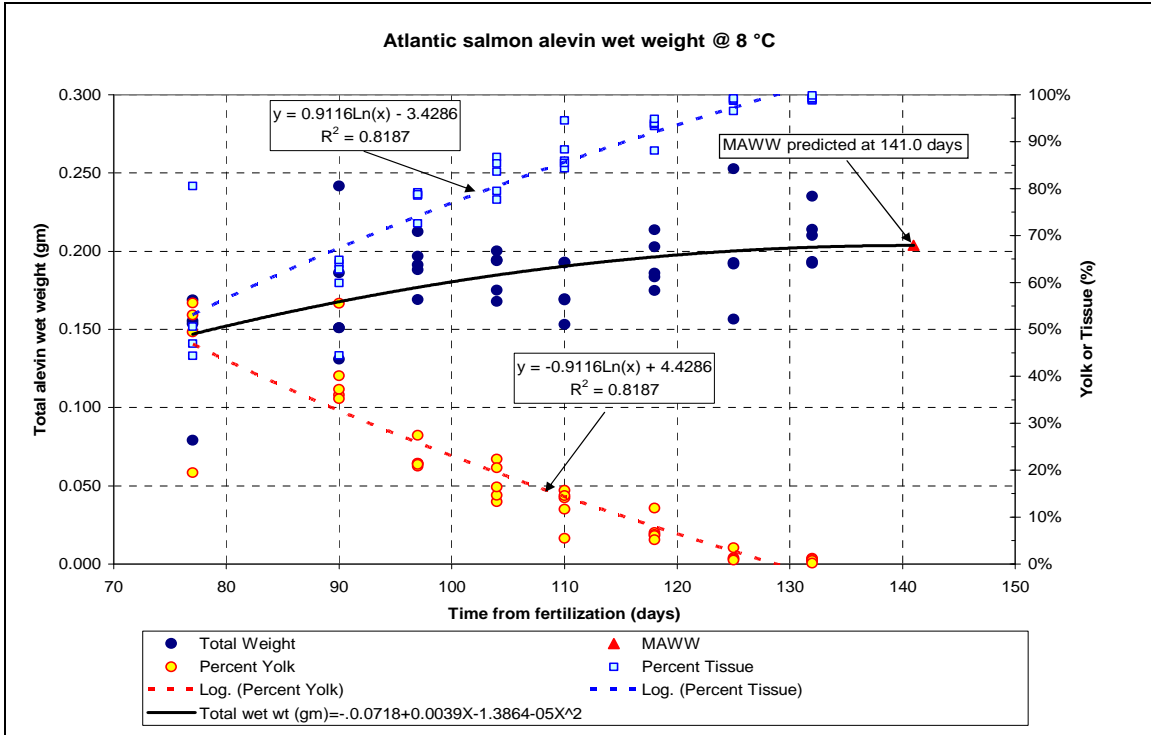

**Figure 5-4.** Atlantic salmon wet weight (gm) and yolk and tissue weights (%).

Time to 10% and 0% yolk (based on wet weights) was modelled for 4 to 12 °C, along with MAWW for 8 to 12 °C (Fig. 5-5).

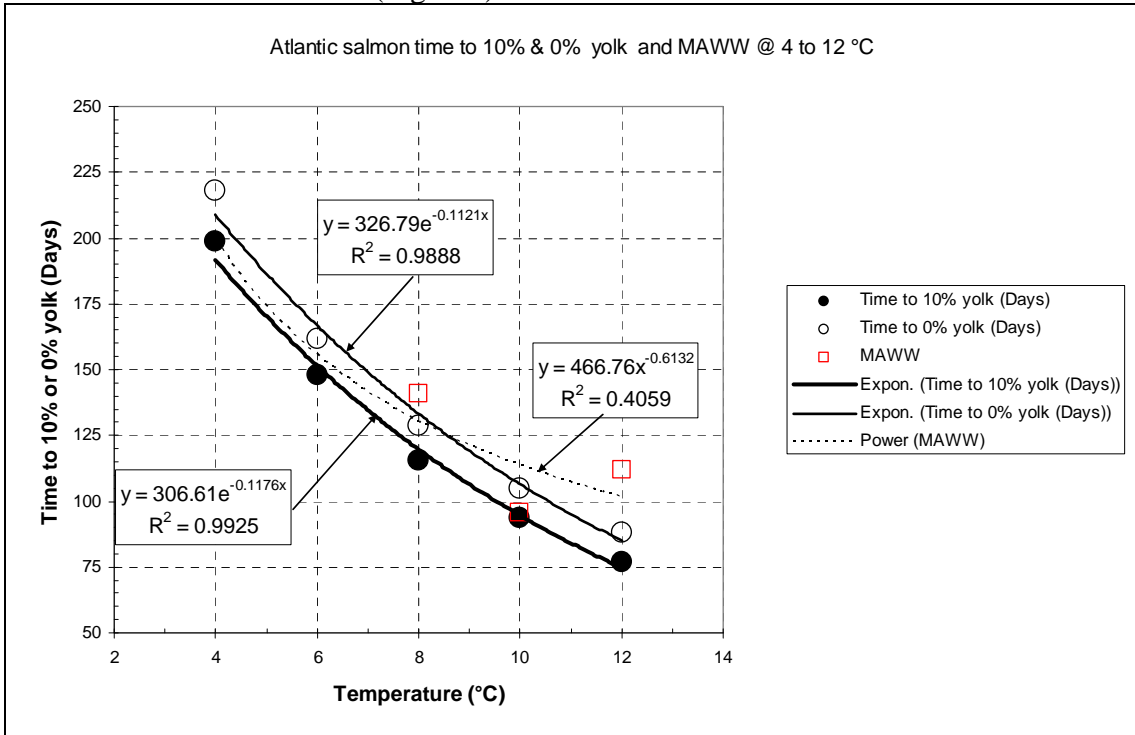

**Figure 5-5.** Atlantic salmon time to 10% and 0% yolk and MAWW models versus temperature ranging from 4 to 12 °C.

Embryonic stages of development were photographed from fertilization to complete yolk absorption and are currently being analysed for developmental models. Figure 5-6 illustrates a decapsulated egg at the eyed stage. Figure 5-7 illustrates an abnormal embryo.



**Figure 5-6.** Atlantic salmon embryo at the eyed stage.

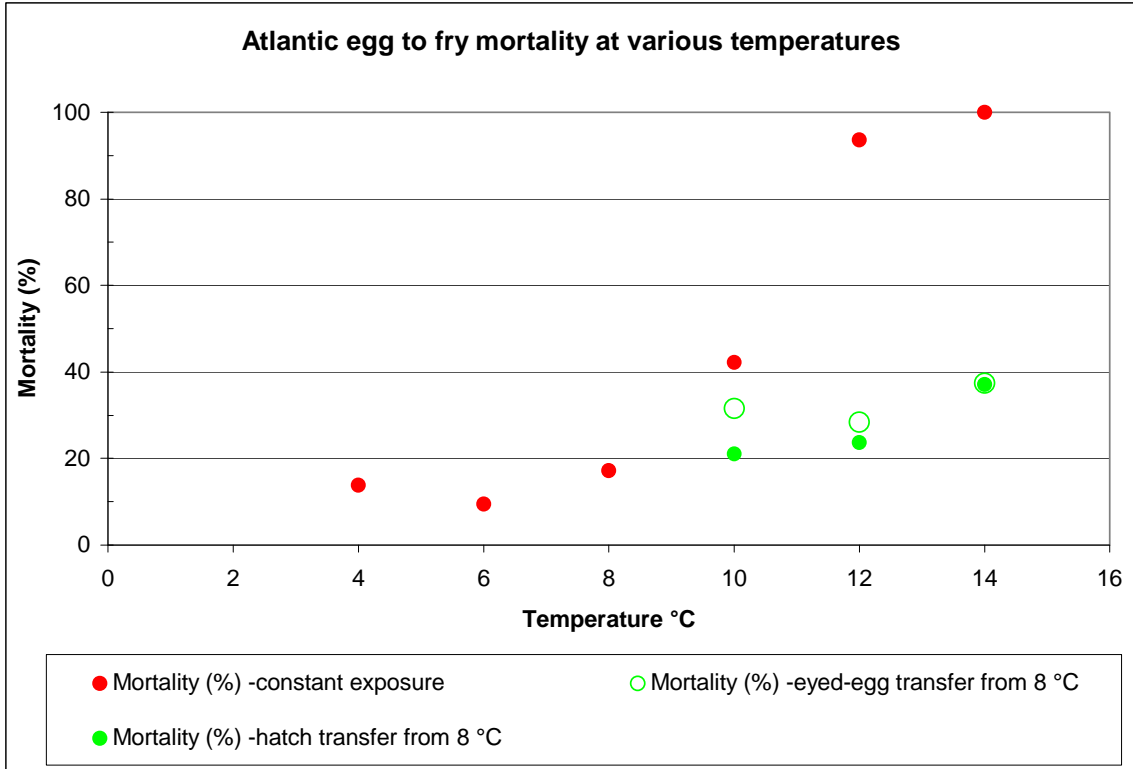

**Figure 5-7.** Abnormal Atlantic salmon embryo.

Transferring eyed eggs and newly hatched larvae from 8 °C to 10, 12, and 14 °C resulted in lower egg to fry mortality compared to constant exposure (Table 5-2 and Fig. 5-8).

**Table 5-2.** Atlantic salmon egg to fry mortality (%) of eyed eggs and newly hatched larvae transferred from 8 °C to 10, 12, and 14 °C and for constant exposure from 4 to 14 °C.

<i>Temperature (°C)</i>	<i>Mortality (%) constant exposure</i>	<i>Mortality (%) Eyed-egg transfer from 8 °C</i>	<i>Mortality (%) hatch transfer from 8 °C</i>
4	13.8		
6	9.5		
8	17.2		
10	42.2	31.5	21.1
12	93.6	28.4	23.7
14	100.0	37.4	37.1



**Figure 5-8.** Atlantic salmon egg to fry mortality comparison at constant temperatures compared to eyed eggs and newly hatched larvae transferred from 8 °C to 10, 12, and 14 °C.

Oxygen consumption measurements for eggs and larvae incubated at 4 to 10 °C were modelled (Fig. 5-9) and show an increase with both time and temperature.

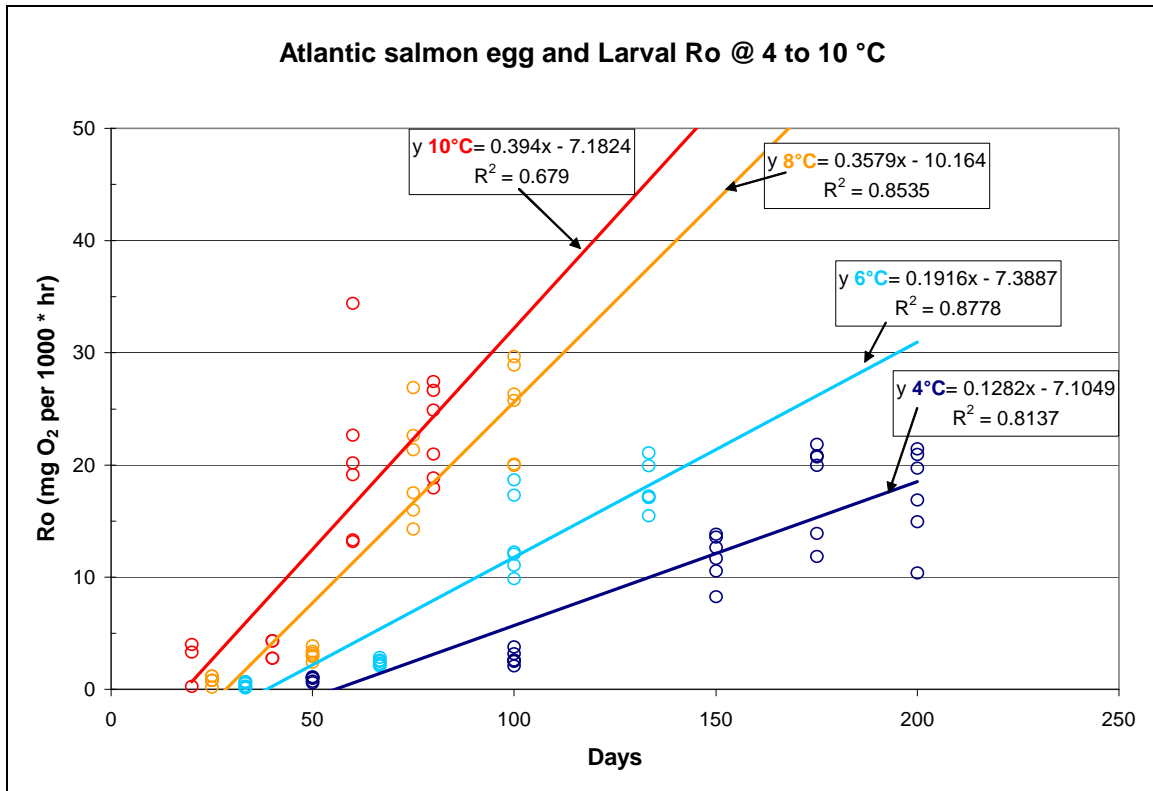

**Figure 5-9.** Atlantic salmon egg and larval oxygen consumption (Ro; mg O<sub>2</sub> per 1000 \* hr) at 4, 6, 8, and 10 °C.

## 5.5 Discussion

Results from the first of two years' of work have been presented in this paper, with the understanding that models and conclusions may change after analyses of results from the second year. The egg to fry mortality (Fig. 5-2) results for year 1 of our study indicated that mortality increased sharply between 8 and 10 °C, with 100 % mortality observed at 14 °C. The provisional model from these data suggests an optimum incubation temperature of 5.74 °C.

The provisional hatching model predicted time to 50% hatch very well (Fig. 5-3), with days to hatch ranging from 122 to 35 days, at 4 and 12 °C, respectively. Figure 5-3 also illustrates that the ATU model is not constant, and that if extrapolated to the low temperature of 2 °C, the ATU model would incorrectly predict 50% hatch by 47 days too late.

The growth models (Fig. 5-4 & 5-5) for tissue and yolk were highly significant, with  $r^2$  values ranging from 0.8187 to 0.9925. The MAWW model (Fig. 5-5) was not as robust, but still is useful as a first estimate. A second series of incubation tests (test temperatures of 3, 4, 5, 6, 7, 8, 9, 10, and 11 °C) were conducted in 2003-2004, and have just been completed in October. Mortality and developmental data from this latter series have yet to be analyzed.

The incidence of abnormalities was low (i.e. <1%) in our tests. A larger-scale assessment of abnormalities in industry production incubation hatcheries is currently underway.

The experiment conducted to test the possible improvement in egg to fry survival at higher incubation temperatures showed promise, with both eyed-egg transfers and newly hatched larval transfers to 12 and 14 °C resulting in mortality reductions of over 60% (Table 5-2 and Fig. 5-8). A second series of transfer experiments (i.e. from 6 and 8 °C to 9, 10, and 11 °C at eyed and hatch) were conducted in 2003 to 2004. Mortality and developmental data are currently being analyzed.

The oxygen consumption models (Fig. 5-9) were highly significant, with  $R^2$  values ranging from 0.6790 to 0.8778. These models can be used by fish culturists, scientists, or fisheries managers to aid in predicting changes in Atlantic salmon egg and larval metabolic rates in response to temperature and stage of development. For Atlantic salmon fish culture, this means that for a given flow rate, temperature, inflow dissolved oxygen level, and egg or larval load rate, dissolved oxygen levels at the outflow of an incubator can be calculated. Hence, by adjusting the above parameters, adequate oxygen levels can be easily maintained in a production setting, ensuring low mortality and abnormality levels, and optimum conditions for growth. Such oxygen consumption models for Pacific salmon were discussed by McLean et al. (1991).

The objective of this research was to provide new information to Atlantic salmon fish culturists. The results, models, and conclusions should be useful in understanding the impact of temperature on egg and larval development, growth, and survival. When the second year's work has been analyzed and new models have been developed, the new findings will be incorporated into our computer program called WinSIRP (i.e. Windows Salmonid Incubation and Rearing Programs) (Jensen et al. 2002) that is available at this web site [http://www-sci.pac.dfo-mpo.gc.ca/aqua/sirp/incubwin\\_e.htm](http://www-sci.pac.dfo-mpo.gc.ca/aqua/sirp/incubwin_e.htm).

## **5.6 Acknowledgements**

Funding for this project was made available through collaboration with Fisheries and Oceans Canada, Pan Fish Canada Ltd., and Stolt Sea Farm Ltd. Also, thanks go to the Pan Fish Canada staff involved in obtaining and transporting the Atlantic salmon gametes used in these tests.

## **5.7 References**

- Beacham, T.D., and Murray, C.B. 1990. Temperature, egg size, and development of embryos and alevins of five species of Pacific salmon: a comparative analysis. *Trans. Amer. Fish. Soc.* 119: 927-945.
- Billard, R., and Jensen, J.O.T. 1996. Gamete removal, fertilization and incubation. In *Principles of salmonid culture*. Eds. W. Pennell and B.A. Barton, Elsevier publ. 291-364.

- Gunnes, K. 1979. Survival and development of Atlantic salmon eggs and fry at three different temperatures. *Aquaculture* 16: 211-218.
- Jensen, J.O.T., Mclean, W.E., Sweeten, T., and Jensen, M.E. 2002. WinSIRP: New Microsoft Windows®-based salmonid incubation and rearing programs, designed for Microsoft Excel®. *Incubation of Fish: Biology and Techniques. Proc. Int. Fish. Phys. Symp.*, July 22-25, 2002, UBC, Vancouver, BC, Canada. Pages 21-36. Available as a PDF file at the following web site:  
<http://www-heb.pac.dfo-mpo.gc.ca/congress/2002/Incubation/incubation.htm>
- McLean, W.E., Jensen, J.O.T., and Rombough, P.J. 1991. Microcomputer models for salmonid hatcheries. *American Fisheries Society Symposium* 10: 516-528.
- Peterson, R.H., Spinney, H.C.E., and Sreedharan, A. 1977. Development of Atlantic salmon (*Salmo salar*) eggs and alevins under varied temperature regimes. *J. Fish. Res. Board Can.* 34: 31-43.
- Velsen, F.P.J. 1987. Temperature and incubation in Pacific salmon and rainbow trout: compilation of data on median hatching time, mortality, and embryonic staging. *Can. Data Rep. Fish. Aquat. Sci.* 626: 58 p.